

TO: Historic Landmarks Commission

THROUGH: Lisa Anderson-Ogilvie, AICP, Deputy Community Development Director and Planning Administrator

FROM: Jake Morris, Preservation Planner

HEARING DATE: October 17, 2024

CASE NO.: Historic Design Review Case No. HIS24-19

APPLICATION SUMMARY: A proposal to install a reconstruction of the historic "ELSINORE" blade sign c.1928 and restore aspects of the marquee and entrance area of the Elsinore Theatre.

LOCATION: 170 High Street SE

REQUEST: A Class 3 Major Historic Design review of a proposal to install a reconstruction of the c. 1928 historic "Elsinore" blade sign, install more period appropriate lighting to replace non-historic fixtures, add 2 message boards on the marquee, and replace deteriorated non-historic tile in the entrance alcove and door hardware on the Elsinore Theatre (1926), a historic contributing building in Salem's Downtown Historic District, zoned CB (Central Business District), and located at 170 High Street SE; 97301; Marion County Assessor's Map and Tax Lot number: 073W27AB02100.

APPLICANT: Historic Elsinore Theatre (Tom Fohn)

APPROVAL CRITERIA: Salem Revised Code (SRC) 230.65 General Guidelines for Contributing Resources

RECOMMENDATION: **DENY** the electronic message boards.

APPROVE the remainder of the proposal.

BACKGROUND

On September 3, 2024, the applicant submitted materials for a Major Historic Design Review for a proposal to install a reconstruction of the c. 1928 historic "Elsinore" blade sign, install reproductions of decorative roof parapet elements, install more period appropriate lighting to replace non-historic fixtures, add 2 message boards on the marquee, and replace deteriorated non-historic tile in the entrance alcove and door hardware on the Elsinore Theatre (1926), (**Attachment B**). Staff requested additional information on September 16, 2024, which was provided September 19, 2024. The application was deemed complete for processing on September 25, 2024.

Notice of public hearing was sent by mail to surrounding property owners and tenants pursuant to Salem Revised Code (SRC) requirements on September 27, 2024. Public hearing notice was also posted on the property in accordance with the posting provision outlined in SRC 300.620. The City of Salem Historic Landmarks Commission will hold a public hearing for the case on October 17, 2024 at 5:30 p.m. in Council Chambers, Civic Center at 555 Liberty Street SE, Room 240. (<https://bit.ly/planningpublicmeetings>).

The state-mandated 120-day deadline to issue a final local decision, including any local appeals in this case is January 23, 2025, unless an extension is granted by the applicant.

PROPOSAL

The applicant is requesting approval to reconstruct the c. 1928 historic "Elsinore" blade sign, install reproductions of decorative roof parapet elements, install more period appropriate lighting to replace non-historic fixtures, and replace deteriorated non-historic tile in the entrance alcove and door hardware on the Elsinore Theatre (1926). Additionally, the applicant proposes to install two electronic message boards on the marquee. Specific elements of the proposal are as follows:

- Blade Sign:** A reconstruction of the historic "Elsinore" vertical blade sign, based on c. 1930 photographs of the historic sign (Exhibits A and B) that was present on the building until replaced c. 1970 with a different design which was then also removed in 1983 (Exhibit C). Sign body is painted aluminum approximately 23 feet by 4 feet by 12 inches wide. Perimeter and lettering are open channel finished white inside and gold outside. The body color is cast bronze. Lighting consists of S14 LED sign bulbs designed to mimic historic incandescent sign bulbs in appearance and illumination characteristics. Sign to be affixed in historic location on the building.
- Top Structures:** A reconstruction of the historic pediment ornamentation based on historic photographs c. 1928 (Exhibits A and B). Design consists of ornamental crown/balustrades with vertical pickets capped with finials, each connected with panels featuring pointed arch cutouts. Center assembly is crown shaped and the side assemblies are flat, to match historic appearance. All to be constructed of painted aluminum.
- Marquee:** Overall structure of marquee to be refinished in kind except for the following details: Install reproduction shades based on c. 1928 image to the currently bare perimeter drop lights. Each proposed shade is approximately 4 inches square and constructed of painted aluminum. Replace current globe marquee soffit light fixtures with more accurate schoolhouse fixtures. Add gold accent detail to each soffit panel.
- Entry Alcove:** Propose to refinish doors in-kind, and replace worn non-historic handle plates with slightly more detailed versions. Propose to replace deteriorated red clay floor tile in-kind, and add a logo inlay and gold finished inlay accents to direct traffic to the entrance doors. Propose to replace current non-historic poster holder which is currently non-matching aluminum finished, to one with gold accents to better match the overall level of finish of the building, and sized to fit the historic wall recess.

LED Displays: Propose to install two LED electronic display signs measuring 28" by 96" to the marquee front, flanking the existing Elsinore marquee sign

SUMMARY OF RECORD

The following items are submitted to the record and are available: 1) all materials and testimony submitted by the applicant, including any applicable professional studies such as traffic impact analysis, geologic assessments, stormwater reports, and; 2) materials, testimony, and comments from public agencies, City Departments, neighborhood associations, and the public. All application materials are available on the City's online Permit Application Center at <https://permits.cityofsalem.net>. You may use the search function without registering and enter the permit number listed here: 24 118662.

APPLICANT'S STATEMENT

A request for historic design review must be supported by proof that it conforms to all applicable criteria imposed by the Salem Revised Code. The applicants submitted a written statement, which is included in **Attachment C** in this staff report.

Staff utilized the information from the applicant's statements to evaluate the applicant's proposal and to compose the facts and findings within the staff report. Salem Revised Code (SRC) **Salem Revised Code (SRC) 230.065 General Guidelines for Contributing Resources** are the applicable criteria for evaluation of this proposal.

FACTS & FINDINGS

1. Historic Designation

Under Salem Revised Code (SRC) Chapter 230, no development permit for a designated historic resource shall be issued without the approval of the Historic Landmarks Commission (HLC). The HLC shall approve, conditionally approve, or deny the application on the basis of the project's conformity with the criteria. Conditions of approval, if any, shall be limited to project modifications required to meet the applicable criteria.

According to SRC 230.020(f), historic design review approval shall be granted if the application satisfies the applicable standards set forth in Chapter 230. The HLC shall render its decision supported by findings that explain conformance or lack thereof with relevant design standards, state the facts relied upon in rendering the decision, and explain justification for the decision.

2. Historic Significance

The Elsinore Theatre was constructed in 1926 by George B. Guthrie in the Tudor Gothic style. The designer of this theatre was Ellis F. Lawrence of the Portland firm of Lawrence and Holford. Lawrence is known as the founder and dean of the University of Oregon School of Architecture. The general contractor was local builder Cuyler Van Patten. The building is individually listed on the National Register of Historic Places, while also a contributing building within Salem's downtown historic commercial district. The nomination states: "The Elsinore Theatre is significant as the most intact example of 1920's theatre design in Salem and the only example of a Gothic style theatre of this period within the state of Oregon." It is also significant as the only existing theatre design from the firm of Lawrence and Holford.

3. Neighborhood Association and Public Comments

The subject property is located within Central Area Neighborhood Development Organization (CANDO).

Neighborhood Association Comment: Notice of the application was provided to the neighborhood association pursuant to SRC 300.620(b)(1)(B)(v), which requires notice to be sent to any City-recognized neighborhood association whose boundaries include, or are adjacent to, the subject property. On September 25, 2024, Michael Livingston submitted comments on behalf of CANDO in support of the proposal (Attachment D).

Homeowners Association: The subject property is not located within a Homeowners Association.

Public Comment: Notice was also provided, pursuant to SRC 300.620(b)(1)(B), to all property owners and tenants within 250 feet of the subject property and all property owners within the historic district. At the time of writing this staff report, one public comment in support has been received.

Public Comment: Notice of public hearing was also posted on the subject property.

4. City Department and Public Agency Comments

Building and Safety Division – Reviewed the proposal and commented that building permits are required for this project.

Development Services Division – Reviewed the proposal and recommends that the application be conditioned to obtain any necessary structural Building Permits to ensure that the sign is structurally sound and does not pose a risk to the public right-of-way. They also recommend that a condition of approval be established to ensure the applicant obtain a Revocable License to Encroach prior to issuance of a Building Permit for this sign.

Public Works Department - Did not provide any comments regarding the proposal.

Fire Department - Did not provide any comments regarding the proposal.

Planning Division - Reviewed the proposal and commented that per SRC 900.200 “reconstruction or installation of historic signs in historic districts are not subject to” the standards for free standing signs, hanging signs, projecting signs, roof signs, and wall signs and a sign permit will be required. However, pursuant to SRC 900.070(a), “no electronic display sign shall be allowed within a historic district.” Therefore, staff is compelled to recommend that HLC deny the electronic message boards per SRC 900.070(a).

5. Historic Design Review

Salem Revised Code (SRC) 230.065 *General Guidelines for contributing resources* are the criterion applicable to the evaluation of this proposal. Historic Landmarks Commission staff reviewed the project proposal and have the following findings for the applicable standards.

FINDINGS

230.065. GENERAL GUIDELINES FOR HISTORIC CONTRIBUTING RESOURCES

(a) Except as otherwise provided in this Chapter, the property shall be used for its historic purpose, or for a similar purpose that will not alter street access, landscape design, entrance(s), height, footprint, fenestration, or massing.

Finding: Property is used as a theater/performing arts center. This is a continuation of the historic purpose of the resource. Staff recommends that the HLC find that SRC 230.065(a) has been met.

(b) Historic materials, finishes and distinctive features shall, when possible, be preserved and repaired according to historic preservation methods, rather than restored.

Finding:

Although the current marquee and entry/ticket area visually resemble the appearance of the theatre during the historic period, these elements were restored in 1983, reversing previous alterations. Historic images taken in the mid-1970s depict a marquee and entrance alcove that had been heavily modified, which removed or damaged related historic materials, finishes and distinctive features. Since the original materials no longer exist, preservation and repair are no longer options, leaving restoration as the most sensitive viable treatment, since the historic design is retained.

Similarly, the most recent rooftop parapet ornamentation was made of wood as a replacement for the original terra cotta and was likely installed in 2002. Photos suggest that this was the third iteration of these distinctive, architectural pieces. After 20 years, the most recent pieces required removal for safety. Therefore, restoration of this design feature is the most sensitive remaining treatment.

The proposed Elsinore blade sign is a reconstruction of a missing distinctive feature, so no historic materials, finishes or distinctive features are available. Reconstruction is the only available treatment to restore the historic visual appearance of the theatre.

Based on this analysis, staff recommends that the HLC find that SRC 230.065(b) has been met.

(c) Distinctive stylistic features or examples of skilled craftsmanship significance shall be treated with sensitivity.

Finding: The portions of the proposal related to reconstructing the parapet and “Elsinore” blade sign elements are not impacting historic materials, instead they are replacing missing features, therefore the craftsmanship embodied in any historic material assemblies are not impacted. However, the treatments proposed retain the features necessary to convey the distinctive theme of the theater. The addition of the blade sign will return a stylistic feature integral to the design of this and almost all historic theatres of the era. The remaining aspects of the proposal, such as the proposed alterations of details, such as the added ornamentation to the entrance tile and the marquee soffit pinstriping, are minor, and do not significantly

impact the overall character of the exterior and are consistent with the style of the building. For these reasons, staff recommends that the HLC find that SRC 230.065 (c) has been met.

(d) Historic features shall be restored or reconstructed only when supported by physical or photographic evidence.

Finding: This project does include restoration or reconstruction of features, including the vertical blade sign, the rooftop crown ornamentation, and the under-marquee light fixtures, and tiled wall base. Photographic evidence is included for the following items:

- Vertical “Elsinore” blade sign (Exhibits A and B)
- Rooftop parapet ornamentation (Exhibits A and B)
- School house lights under the marquee (Exhibit E)
- Soffit ornamentation under the marquee (Exhibit D)
- Individual aluminum shades for marquee lightbulbs (Exhibit B)
- Tile base on exterior walls (Exhibit E)

All of the proposed features above relatively closely follow historic images. Only one image has been found that is of an angle that shows how the soffit panels under marquee appeared historically. This angle of this image does not allow close inspection of the exact design, but it does clearly show that there was more ornamental detail historically than currently exists. The pinstripes subtly return some of the level of detail. Therefore, staff recommends that the HLC find that SRC 230.065(d) has been met.

(e) Changes that have taken place to a historic resource over the course of time are evidence of the history and development of a historic resource and its environment and should be recognized and respected. These changes may have acquired significance in their own right, and this significance should be recognized and respected.

Finding: The proposal does not adversely impact any intact features that have acquired significance to the Elsinore. The early 1970s alterations that were reversed in 1983 fall outside of the Period of Significance for the property and district. Therefore, staff recommends that the HLC find that SRC 230.065(e) has been met.

(f) Additions and alterations to a historic resource shall be designed and constructed to minimize changes to the historic resource.

Finding: Overall, the proposal has been designed to restore historically significant features, most notably the sign and parapet elements. Since the sign is proposed to be attached in the same location as the historic sign, installation will require little or no changes to the historic resource.

Other changes, such as the proposed alterations of details like the added ornamentation to the tile and the marquee soffit pinstriping, are only minimal changes that are compatible and do not adversely affect the significant features of the Elsinore. Therefore, staff recommends that the HLC find that SRC 230.065(f) has been met.

(g) Additions and alterations shall be constructed with the least possible loss of historic materials and so that significant features are not obscured, damaged, or destroyed.

Finding: Significant features will not be damaged or destroyed. The blade sign and rooftop features were historic features, so the new installations will use historic attachment points. The entrance tile was similarly installed as a replacement in 1983, so no historic tile is being replaced, but the historic size, color, and field pattern of the historic tile are significant features that are being retained.

Therefore, staff recommends that the HLC find that SRC 230.065(g) has been met.

(h) Structural deficiencies in a historic resource shall be corrected without visually changing the composition, design, texture or other visual qualities.

Finding: The applicant is not proposing to correct any structural deficiencies as part of this proposal; therefore, Staff recommends that the HLC find that this guideline is not applicable to the evaluation of this proposal.

(i) Excavation or re-grading shall not be allowed adjacent to or within the site of a historic resource which could cause the foundation to settle, shift, or fail, or have a similar effect on adjacent historic resources.

Finding: The applicant is not proposing to any excavation or regrading as part of this proposal; therefore, Staff recommends that the HLC find that this guideline is not applicable to the evaluation of this proposal.

RECOMMENDATION

Based upon the information presented in the application, plans submitted for review, and findings as presented in this staff report, staff recommends that the Historic Landmarks Commission:

DENY the electronic message boards.

APPROVE the remainder of the proposal.

DECISION ALTERNATIVES

1. **APPROVE** the proposal as submitted by the applicant and indicated on the drawings.
(Please note that HLC approval of the electronic sign would not override the code provision prohibiting it and would not result in the sign permit being issued.)
2. **APPROVE** the proposal with conditions to satisfy specific guideline(s).
3. **DENY** the proposal based on noncompliance with identified guidelines in SRC 230, indicating which guideline(s) is not met and the reason(s) the guideline is not met.





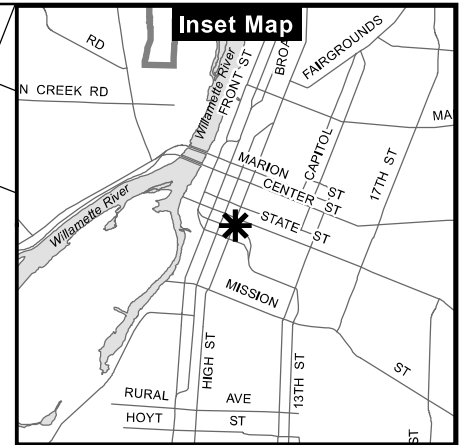
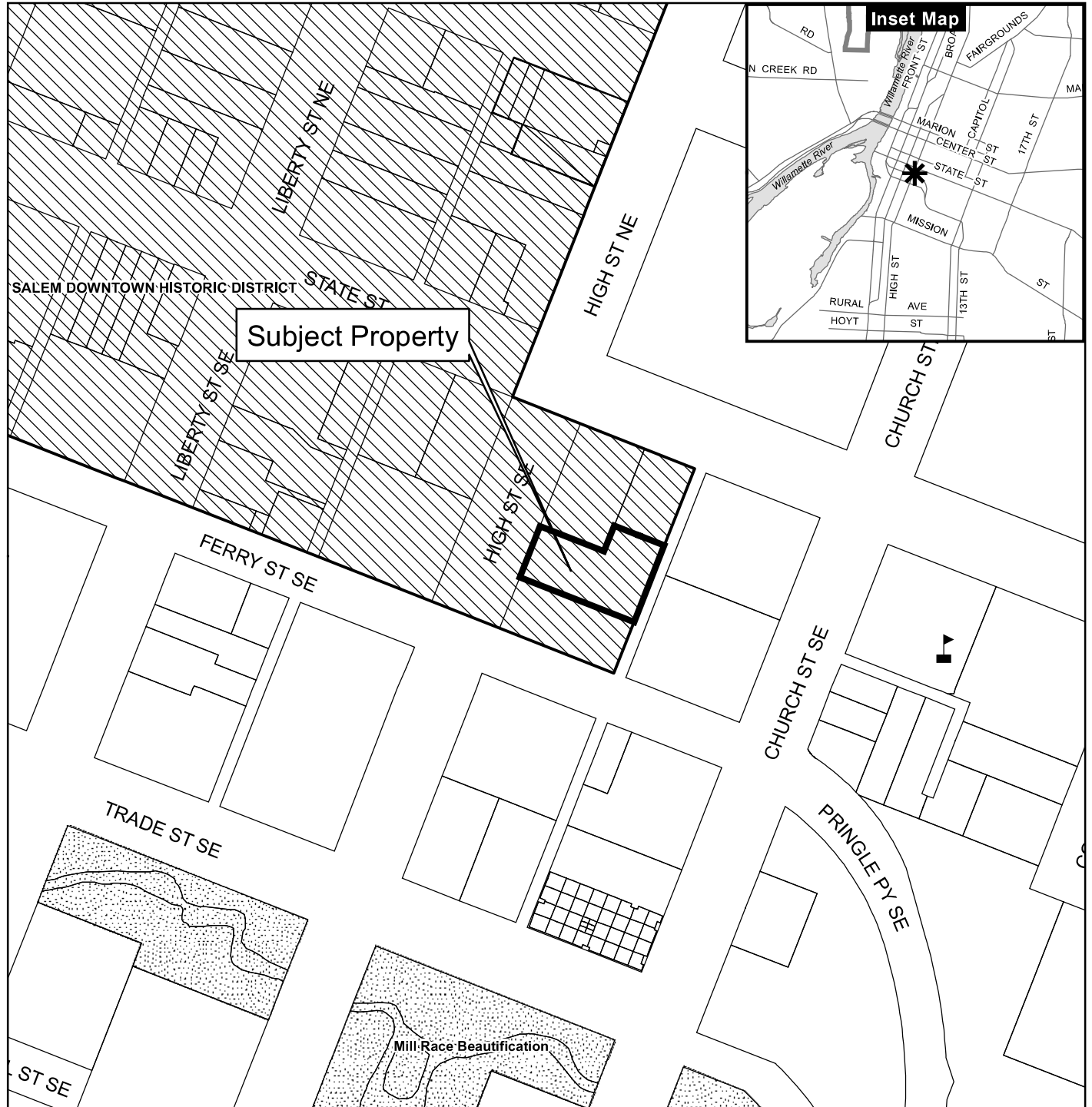

Attachments: A. Vicinity Map
B. Exhibits A-E
C. Applicant's Submittal Materials
D. Comments

Prepared by Jake Morris, Historic Preservation Planner

Vicinity Map 170 High Street SE

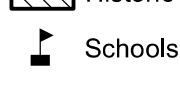

Legend

-  Taxlots
-  Urban Growth Boundary
-  City Limits
-  Outside Salem City Limits
-  Historic District
-  Schools
-  Parks



This product is provided as is, without warranty. In no event is the City of Salem liable for damages from the use of this product. This product is subject to license and copyright limitations and further distribution or resale is prohibited.

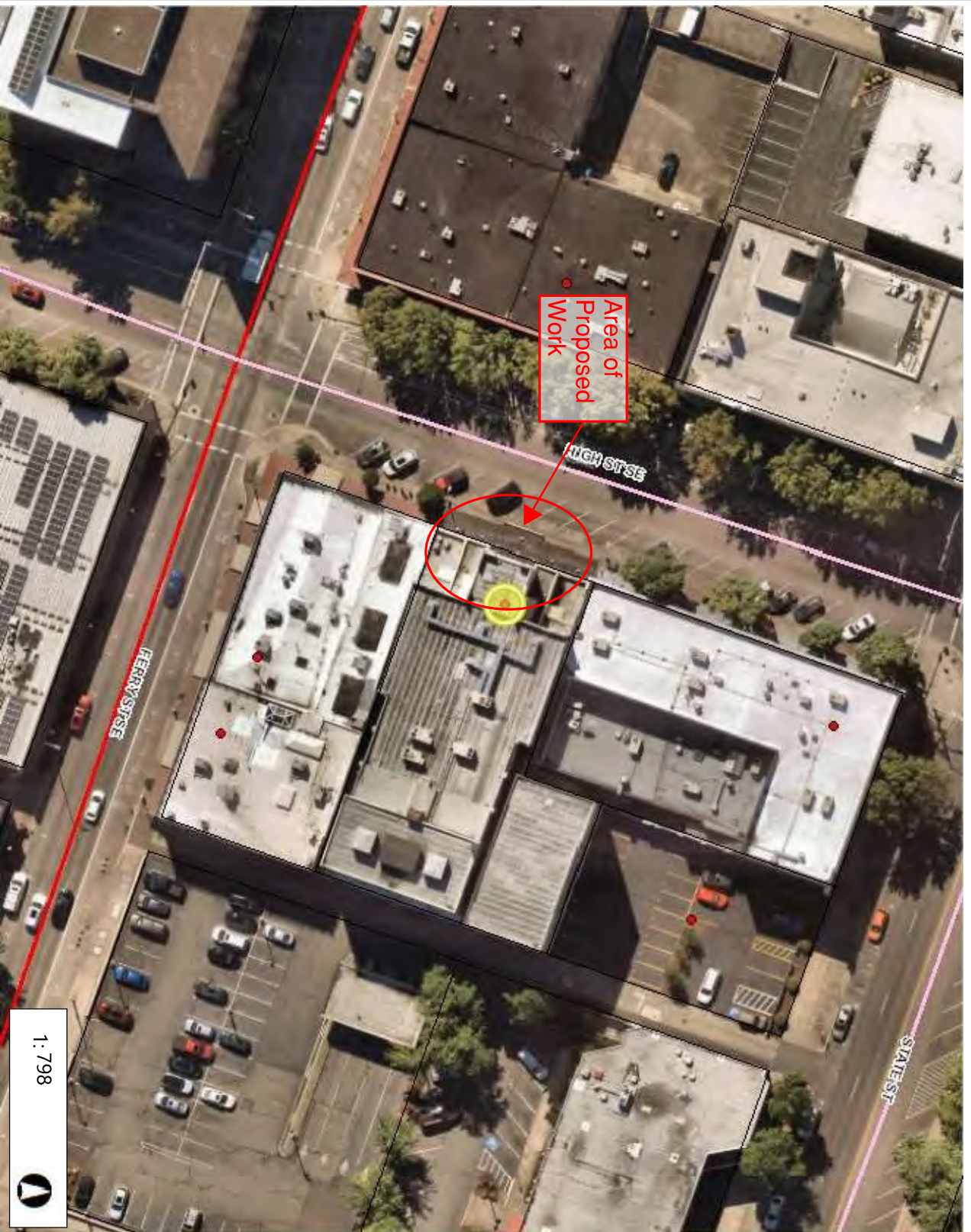

1: 798



0.03
0
0.01
0.03 Miles
WGS_1984_Web_Mercator_Auxiliary_Sphere
City of Salem, Oregon

This map is a user generated static output from an internet mapping site and is for reference only. Data layers that appear on this map may or may not be accurate, current, or otherwise reliable.

THIS MAP IS NOT TO BE USED FOR NAVIGATION

Legend

- ◆ Centerline (Labels)
- ◆ Historic Buildings
- Annexations (delayed)
- Taxlots
- Creeks
- 50 - 200
- 200 - 640
- 640 - 6400
- GT 6400
- Hydrology
- Street Class
- Future Minor Arterial
- Future Collector
- Major Arterial
- Minor Arterial
- Parkway
- Collector
- Highway/Freeway
- Urban Growth Boundary
- City Limit

Notes

Enter notes here...











ATTACHMENT C

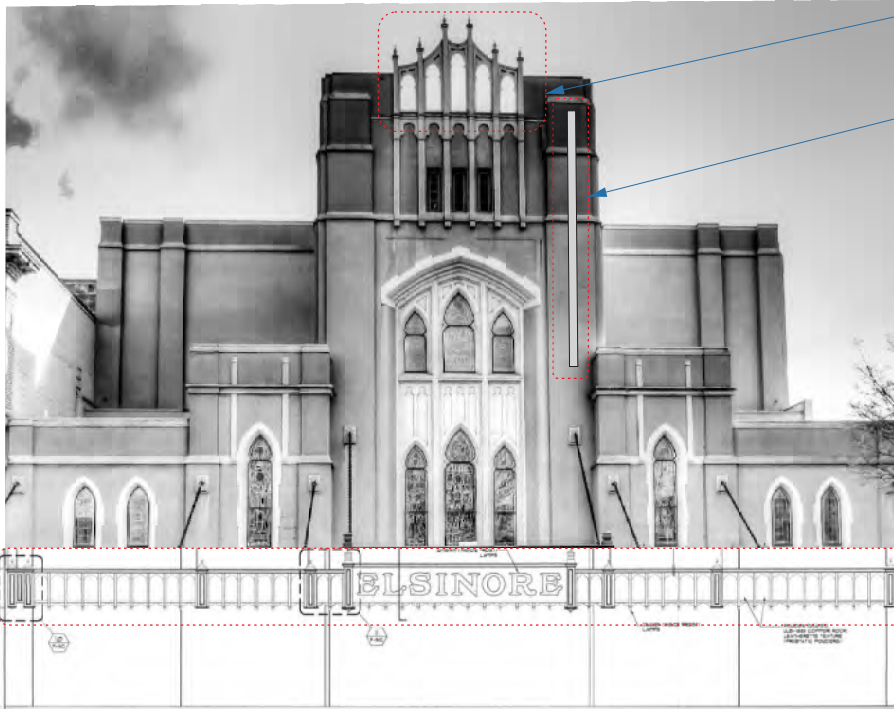

D- NEW TOP STRUCTURES

C- NEW BLADE SIGN

A- MARQUEE RENOVATION

ELEVATION
BACK

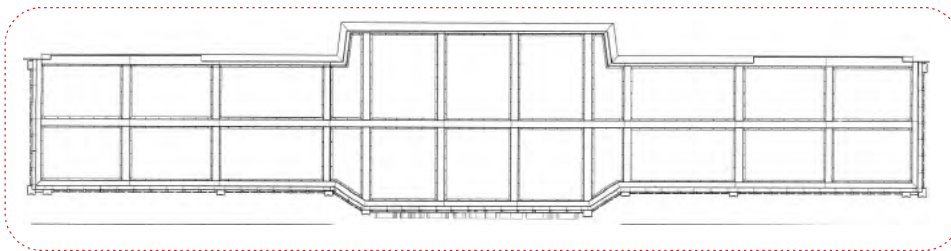

B- SOFFIT RENOVATION



Elsinore Theatre, 170 High St SE, Salem, OR 97301



Final Design SEPT 1 24

5410 Warehouse Way.
Sacramento, CA 95826
916-379-0225
Final Design REV. APRIL 15 24
Final Design REV. JUNE 14 24

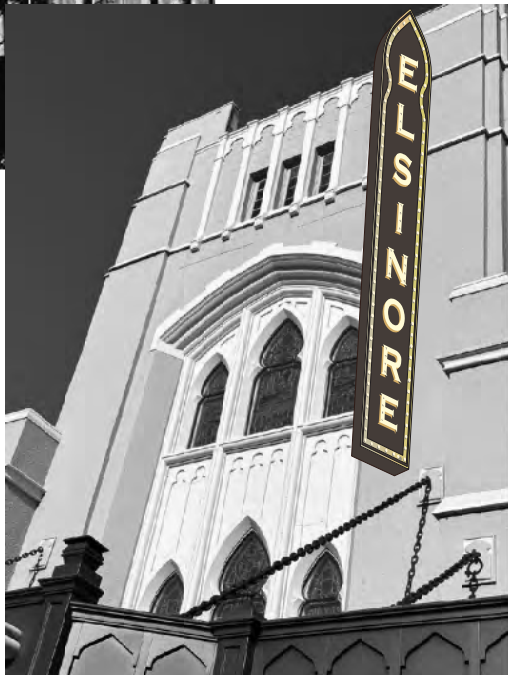

D/F BLADE SIGN

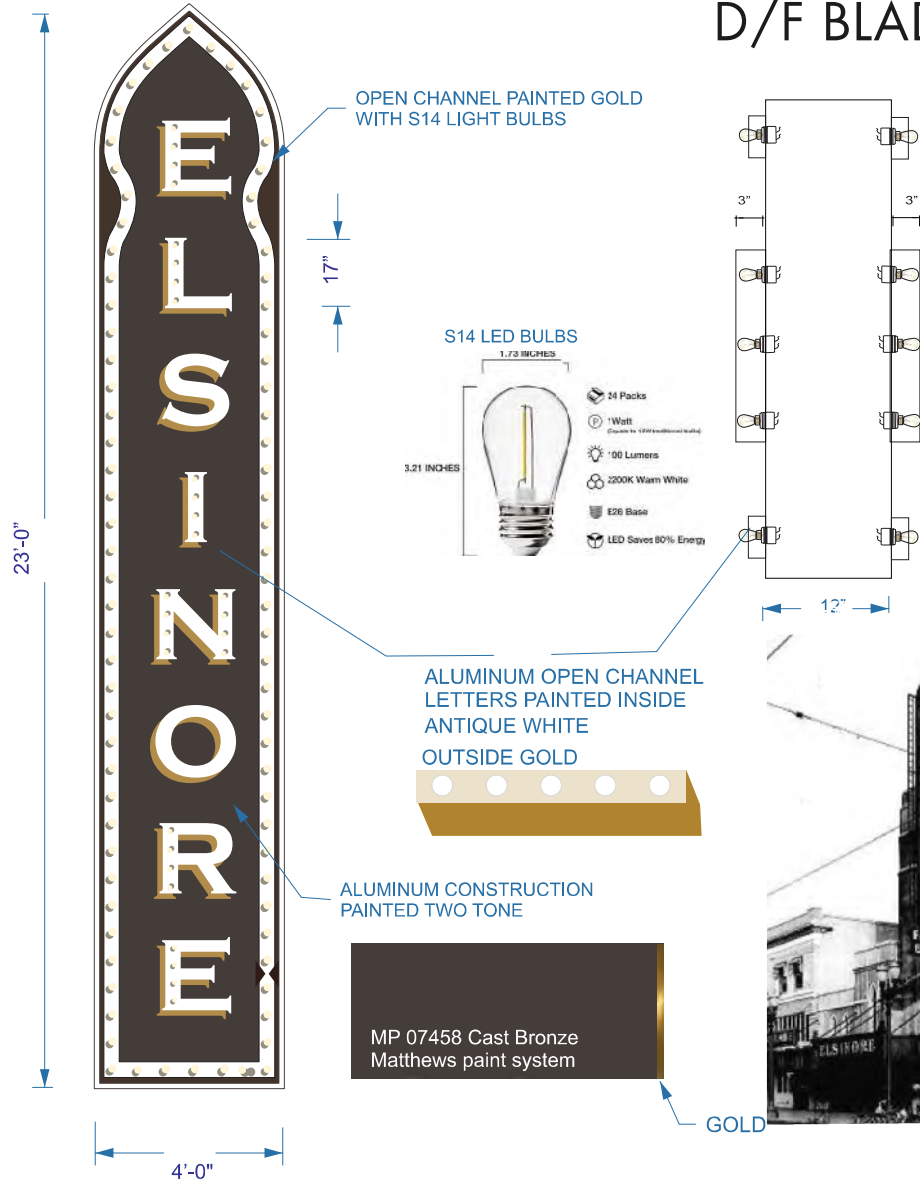

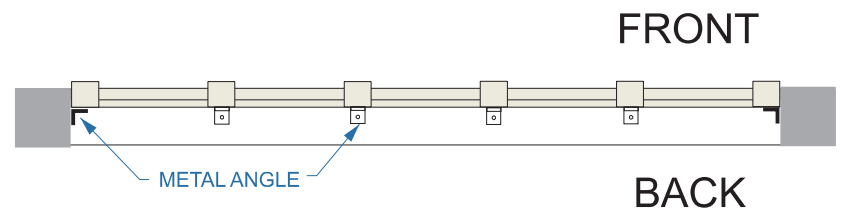

LED DISPLAYS

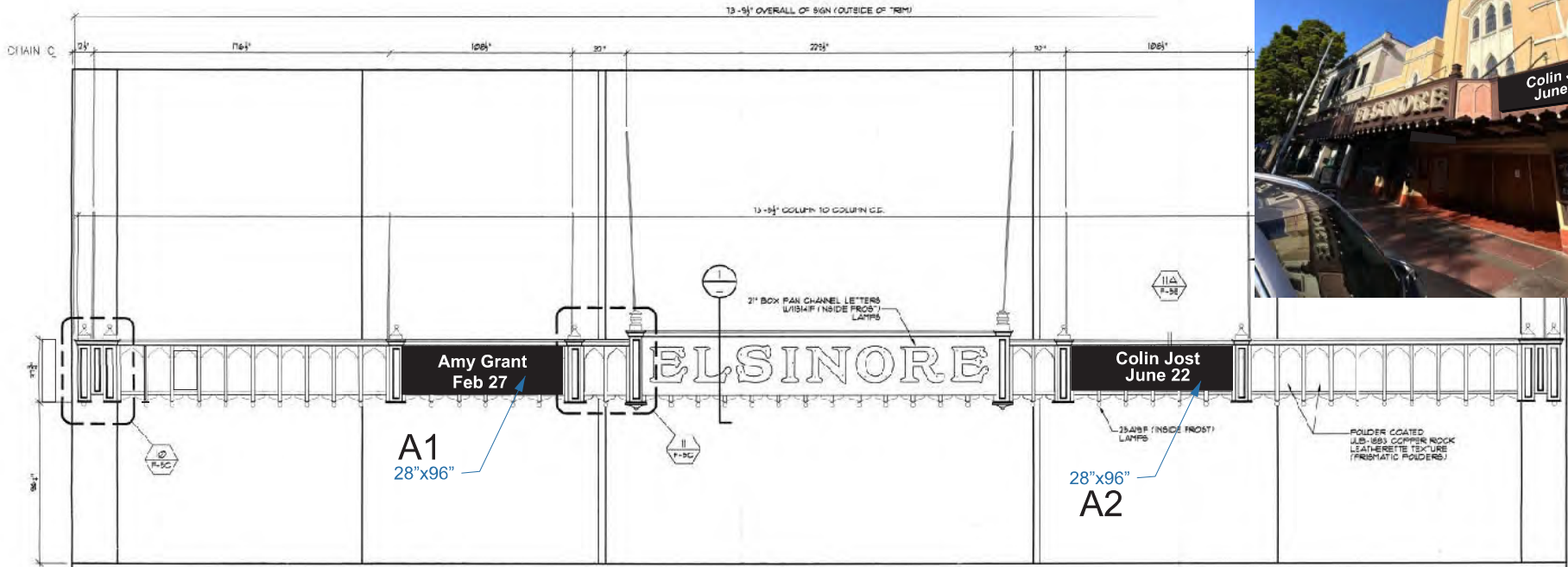
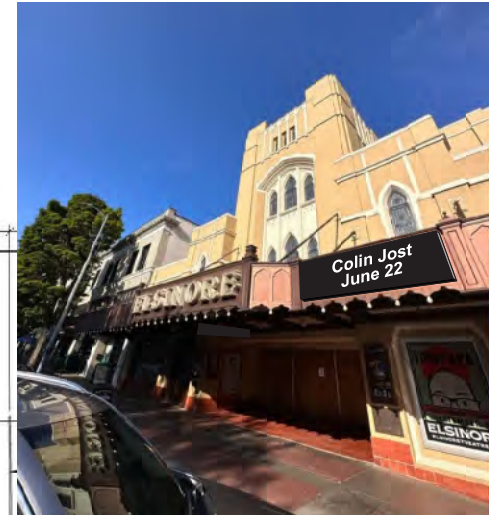

A3
28"x108"

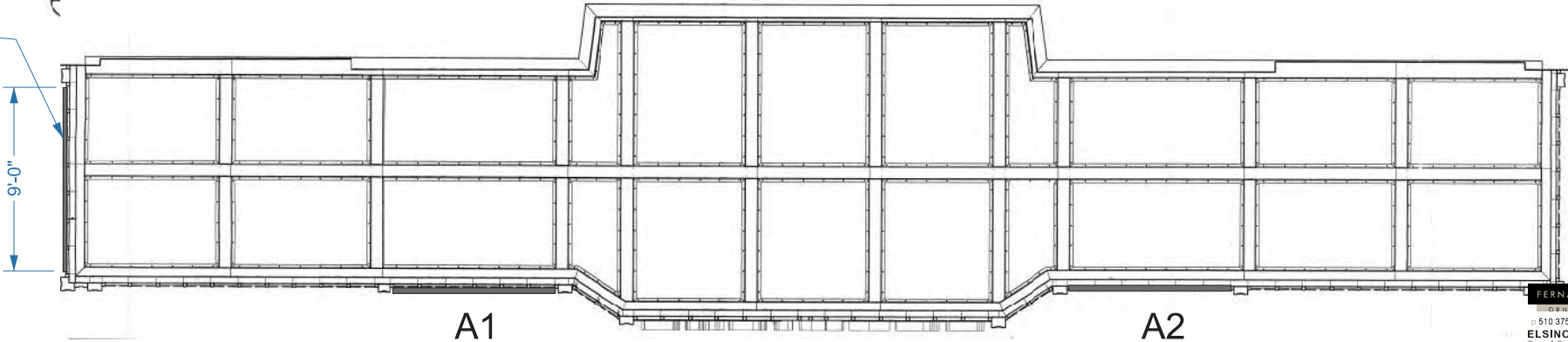

SOFFIT

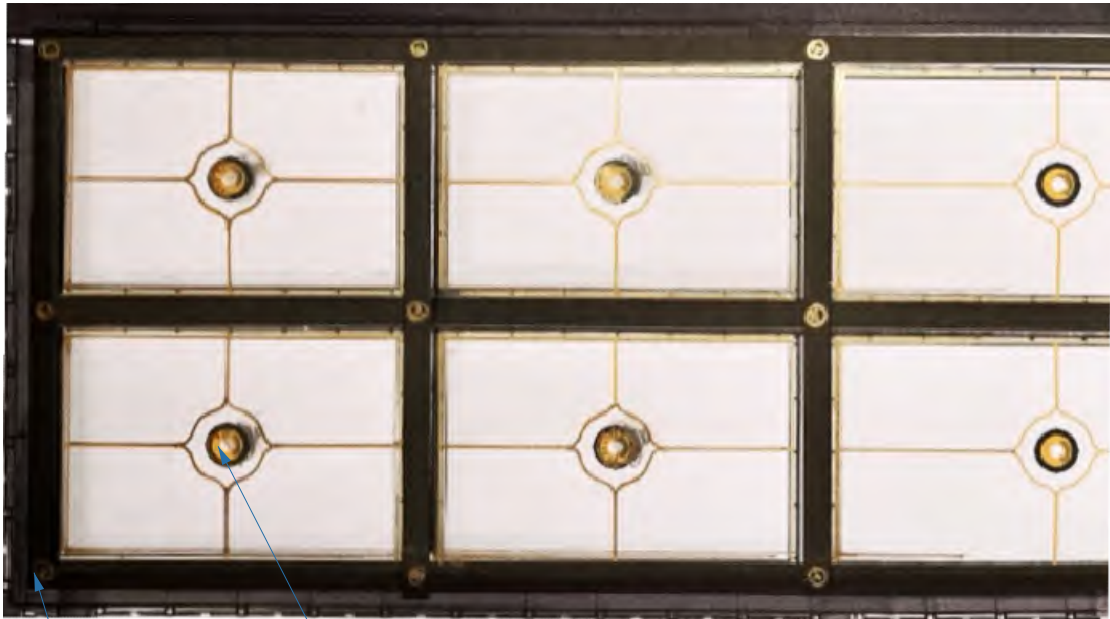

4" METAL ROSSETTE
PAINTED DK COPPER

SCHOOL HOUSE
LAMPS

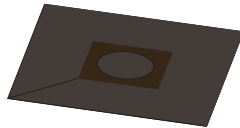

ENTRANCE ELEVATION



Authorization by property owner(s)/applicant

***If the applicant and/or property owner is a Limited Liability Company (LLC), please also provide a list of all members of the LLC with your application.**

Copyright release for government entities: I hereby grant permission to the City of Salem to copy, in whole or part, drawings and all other materials submitted by me, my agents, or representatives. This grant of permission extends to all copies needed for administration of the City's regulatory, administrative, and legal functions, including sharing of information with other governmental entities.

Authorizations: Property owners and contract purchasers are required to authorize the filing of this application and must sign below.

- All signatures represent that they have full legal capacity to and hereby do authorize the filing of this application and certify that the information and exhibits herewith submitted are true and correct.
- I (we) hereby grant consent to the City of Salem and its officers, agents, employees, and/or independent contractors to enter the property identified above to conduct any and all inspections that are considered appropriate by the City to process this application.
- I (we) hereby give notice of the following concealed or unconcealed dangerous conditions on the property:

Electronic signature certification: By attaching an electronic signature (whether typed, graphical or free form) I certify herein that I have read, understood and confirm all the statements listed above and throughout the application form.

Authorized Signature: _____

Print Name: Tom Fohn Date: 8/28/24

Address (include ZIP): 170 High St SE, Salem, OR 97301

Authorized Signature:

Print Name: _____ Date: _____

Address (include ZIP):

| (For office use only) | | |
|-----------------------|-------|-----------------|
| Received by | Date: | Receipt Number: |

Not using Internet Explorer?
Save the file to your computer and email to planning@cityofsalem.net.

Sec. 230.065. - General guidelines for historic contributing resources.

(a) Except as otherwise provided in this chapter, the property shall be used for its historic purpose, or for a similar purpose that will not alter street access, landscape design, entrance(s), height, footprint, fenestration, or massing.

Response: Property is used as a theater/performing arts center. This is a continuation of the historic purpose of the resource.

(b) Historic materials, finishes, and distinctive features shall, when possible, be preserved and repaired according to historic preservation methods.

Response:

Roof ornamentation: The most recent rooftop ornamentation was made of wood and likely installed in 2002. Photos suggest that this was the third iteration of these distinctive, architectural pieces. After 20 years, the most recent pieces began rotting and pieces fell to the sidewalk requiring removal for safety. The new three-dimensional sections will be constructed of aluminum to ensure a much longer life and public safety in the Oregon rain . They have been designed to closely resemble the ones that fell, which were designed after the original terracotta rooftop pieces. To use terracotta today would be cost prohibitive, probably in the \$200,000 range for fabrication vs. \$21,150 in aluminum.

Elsinore blade sign: The proposed sign is a reconstruction of a missing distinctive feature, so no historic materials are being significantly affected. The blade sign, although very similar to the original, has been designed to be 23 feet tall, shorter than original. The original height rose further than the top of the roof. The shorter size was determined by the designer to lessen the weight of the sign for structural purposes.

Marquee: The work to the marquee will remove existing non-historic under-canopy lighting replace with more historically accurate lighting. This will restore the visual appearance closer to historic character.

Entry/Ticket area: The deteriorated flooring tile installed in a previous renovation will be replaced with tile of matching size and color, and door hardware will be replaced with a more accurate replica. This will not impact historic materials.

Overall: The proposed work involves a lot of lighting, but that is consistent with the historic character of this building type. This is an image of the theater at night from the 1930s, and the proposed blade sign and marquee displays, although brighter than currently, will not be as bright overall as the historic

appearance of the theater.



(c) Distinctive stylistic features or examples of skilled craftsmanship significance shall be treated with sensitivity.

Response: The proposed project is not impacting historic materials, but replacing missing ones, or deteriorated previous replacements with more accurate ones. The treatments proposed retain the features necessary to convey the distinctive theme of the theater, as well as the elements that identify it as a historic theater. The addition of the blade sign will return a historic feature integral to theatres that was previously removed.

(d) Historic or original features shall be restored or reconstructed only when supported by physical or photographic evidence.

Response: This project does include restoration or reconstruction of features, including the vertical blade sign, the rooftop crown ornamentation, the under-marquee light fixtures, and wall tile.

Photographic evidence is included for these items as follows:

- Vertical blade sign (excluding Fanchon and Marco letters – a touring vaudeville act in the late 1920's)
- Rooftop crown ornamentation
- School house lights under the marquee
- Individual aluminum shades for marquee lightbulbs
- Tile on exterior walls

(e) Changes that have taken place to a historic resource over the course of time are evidence of the history and development of a historic resource and its environment, and should be recognized and respected. These changes may have acquired historic significance in their own right, and this significance should be recognized and respected.

Response:

The blade sign, although not in existence when the theater opened in May of 1926, was added shortly after, in 1928 (per written recollection), within the period of significance for the theater and the district.

(f) Additions and alterations to a historic resource shall be designed and constructed to minimize changes to the historic resource.

Response:

The blade sign, although very similar to the original, has been designed to be 23 feet tall, shorter than original. The original height rose further than the top of the roof. The shorter size was determined by the designer to lessen the weight of the sign for structural purposes.

(g) Additions and alterations shall be constructed with the least possible loss of historic materials and so that significant features are not obscured, damaged, or destroyed.

Response:

Significant features will not be damaged or destroyed. The blade sign was a historic feature, so the new installation will use historic attachment points. The current deteriorated rooftop ornamentation is a non-historic replica, so the new replacement will not remove historic material. The entrance tile was similarly installed as a replacement, so no historic tile is being replaced, but the historic size and color of the historic tile is being retained.

(h) Structural deficiencies in a historic resource shall be corrected without visually changing the composition, design, texture or other visual qualities.

Response:

No structural deficiencies are presently known.

(i) Excavation or re-grading shall not be allowed adjacent to or within the site of a historic resource which could cause the foundation to settle, shift, or fail, or have a similar effect on adjacent historic resources.

Response:

No regrading or excavation will be occurring.

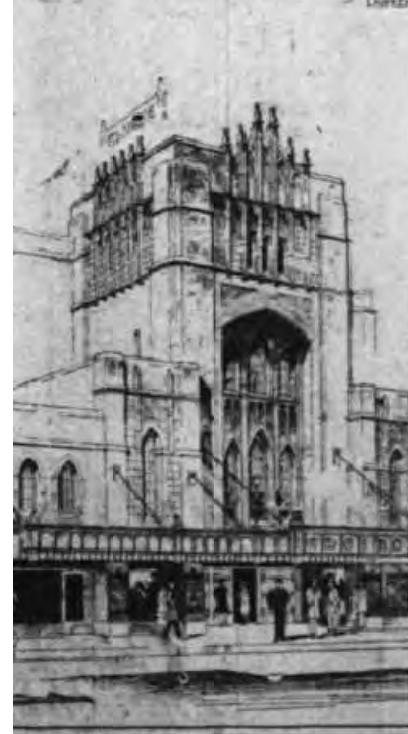

ELSINORE THEATRE

SALEM OREGON



Elsinore Theatre, 170 High St SE, Salem, OR 97301

Final Design SEPT 1 24

Final Design REV. APRIL 15 24
Final Design REV. JUNE 14 24



5410 Warehouse Way.
Sacramento, CA 95826
916-379-0225

DATE: 07-30-24

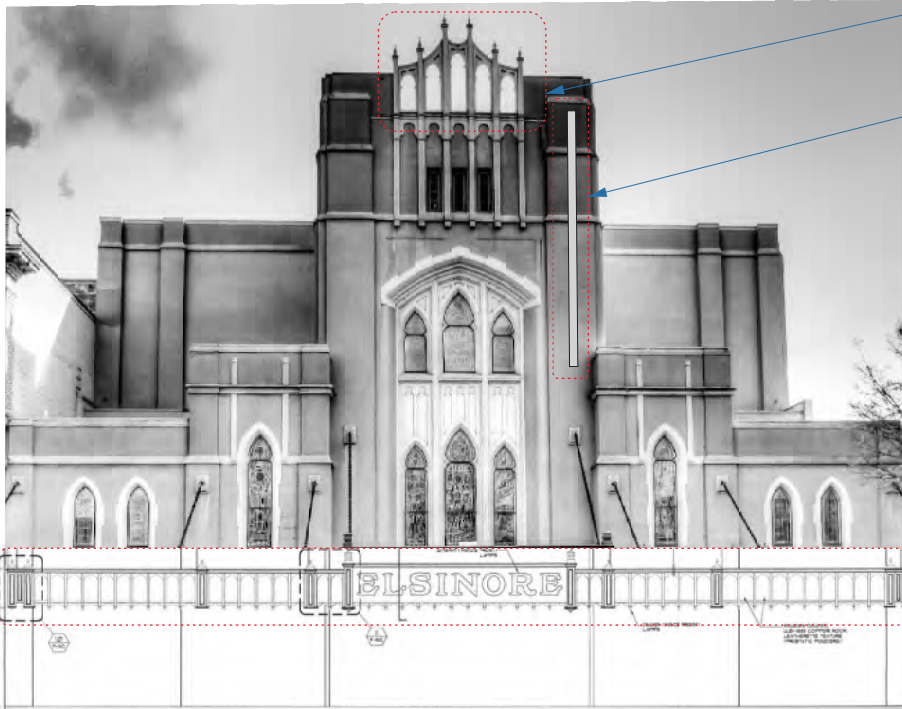

D- NEW TOP STRUCTURES

C- NEW BLADE SIGN

A- MARQUEE RENOVATION

ELEVATION
SCALE 1/8" = 1'-0"

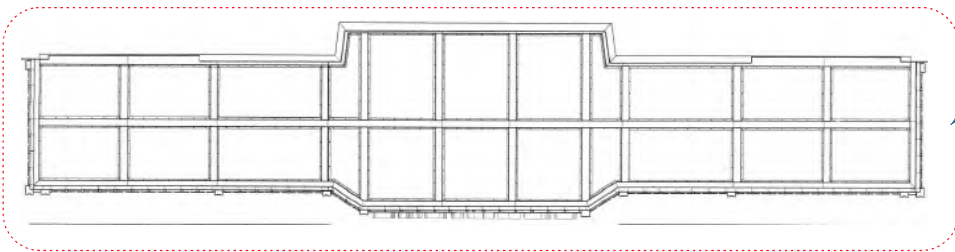

B- SOFFIT RENOVATION



Elsinore Theatre, 170 High St SE, Salem, OR 97301



Final Design SEPT 1 24

5410 Warehouse Way.
Sacramento, CA 95826
916-379-0225

Final Design REV. APRIL 15 24
Final Design REV. JUNE 14 24



1926

And on May 28, 1926, this was the entrance; the opening bill showed "The Volga Boatman," produced by Cecil DeMille and the mighty Wurlitzer played "Finlandia."

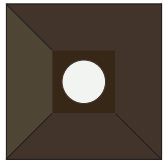
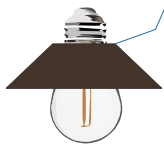

Elsinore Theatre, 170 High St SE, Salem, OR 97301

 AlphaArchitectural
Signs & Lighting

A Division of IEC SERVICES

Final Design SEPT 1 24

5410 Warehouse Way.
Sacramento, CA 95826
916-379-0225

Final Design REV. APRIL 15 24
Final Design REV. JUNE 14 24

1931

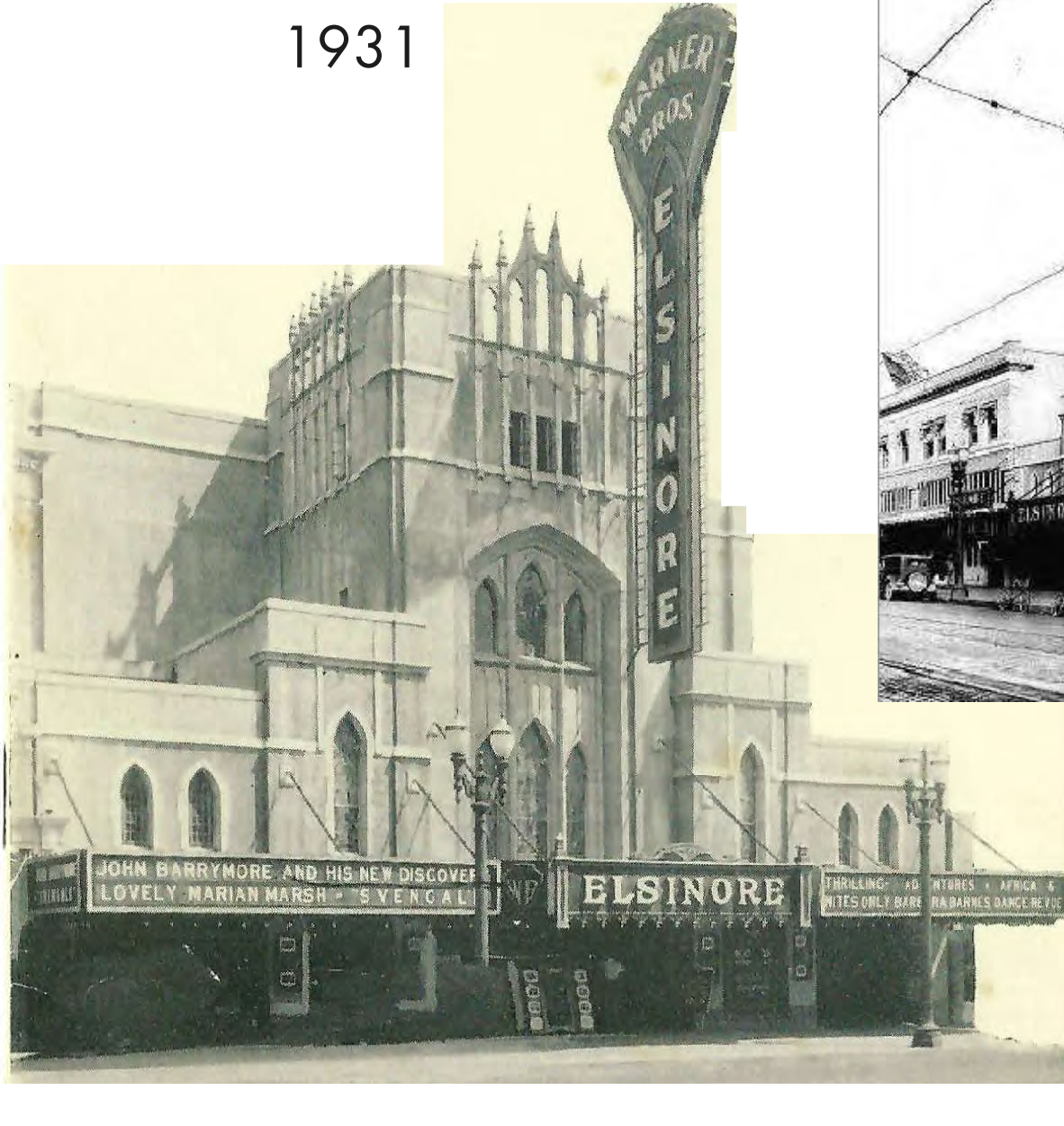

1928

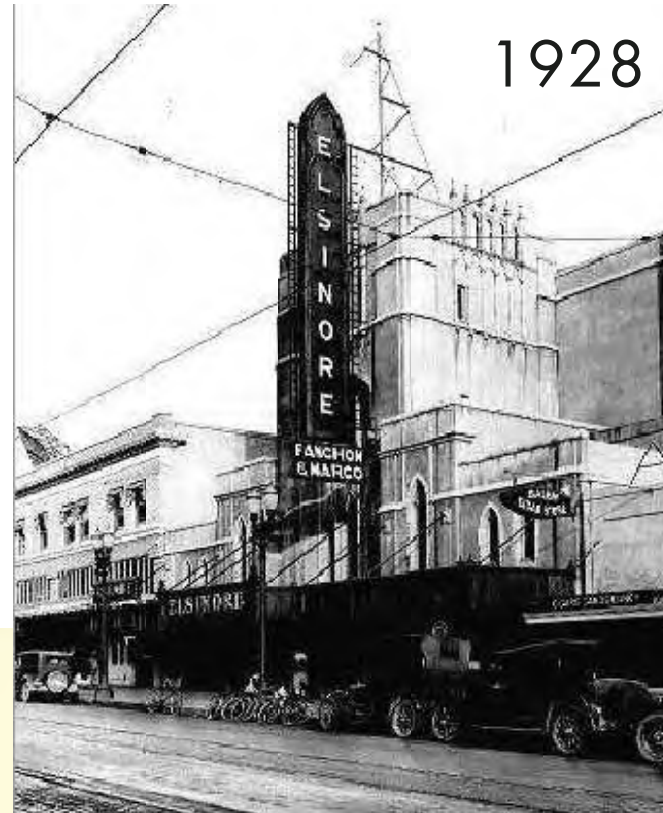

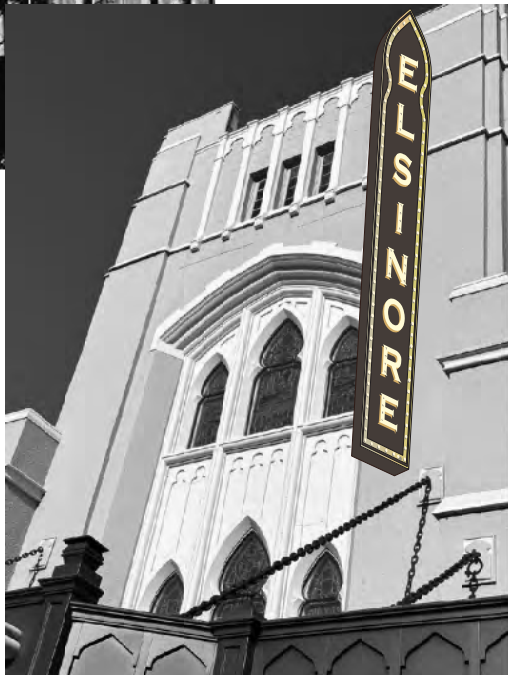

D/F BLADE SIGN

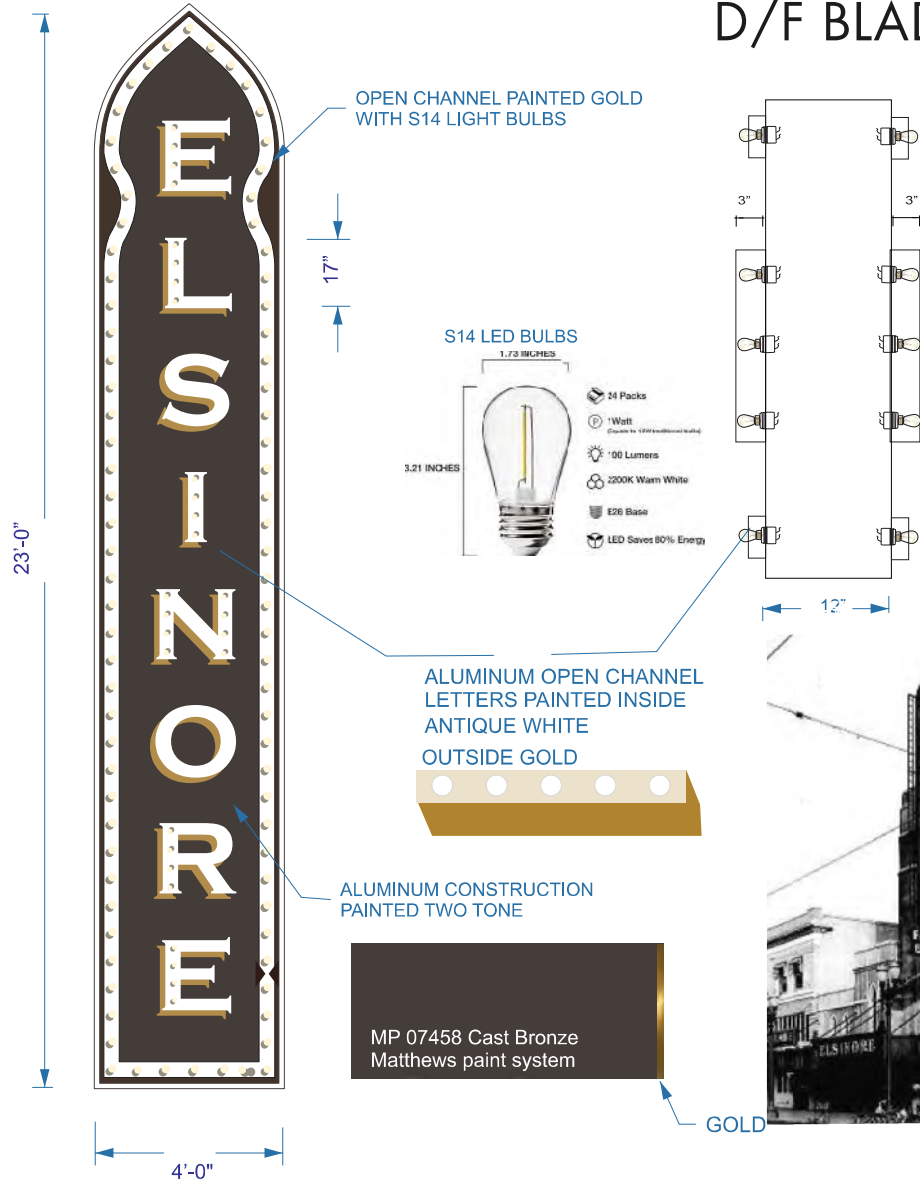

OPTIONAL FLASHERS AND CHASERS

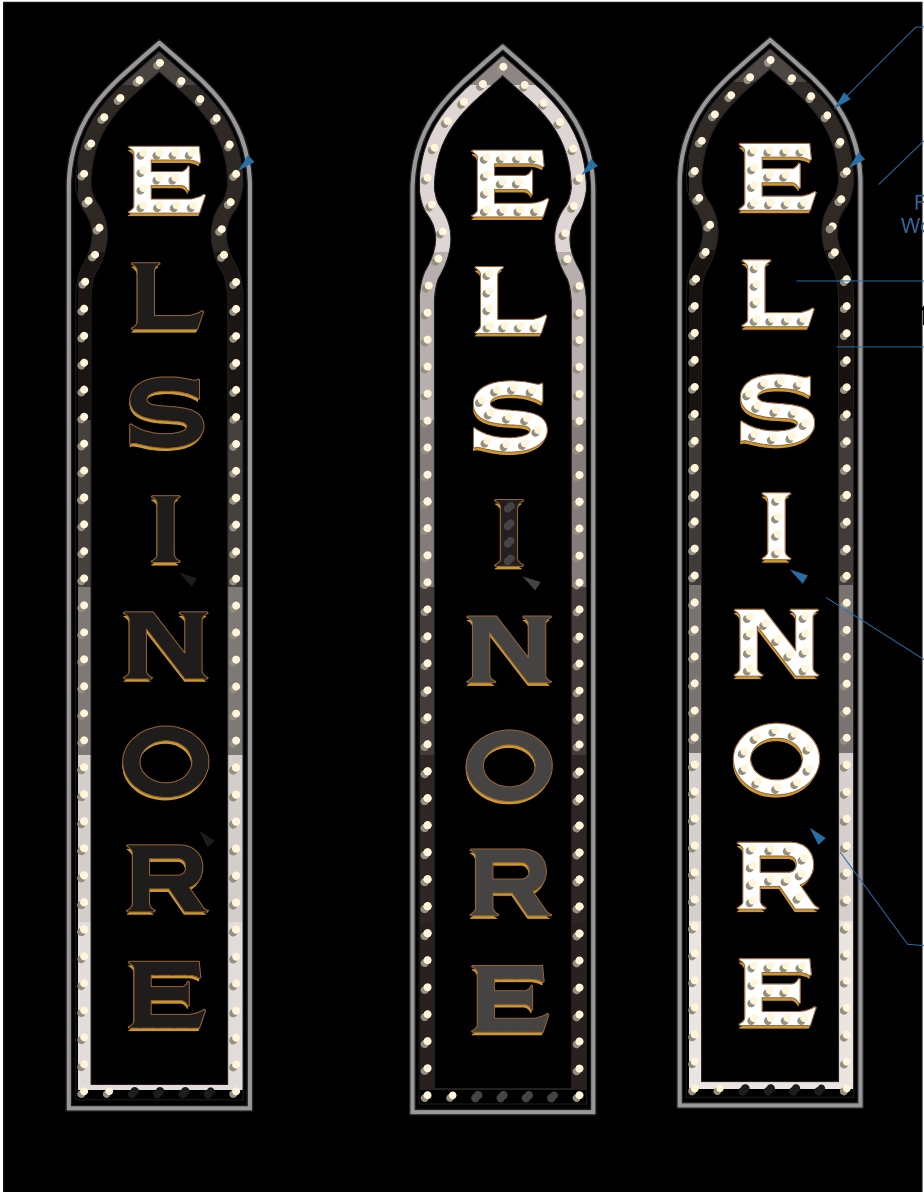

CHASERS AND FLASHERS
AROUND BORDER 3-2 PATTERN
LETTERS ON/OFF

OPEN CHANNEL PAINTED GOLD
WITH S14 LIGHT BULBS

Font Name: LHF
Woodmere Regular

17"

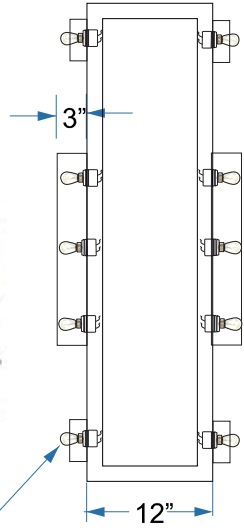

ALUMINUM OPEN CHANNEL
LETTERS PAINTED INSIDE
ANTIQUE WHITE
OUTSIDE GOLD



ALUMINUM CONSTRUCTION
PAINTED TWO TONE

D/F BLADE SIGN

APROX 328 LIGHT BULBS X 1.5 WATT PER BULB
TOTAL WATT 4.1
WE RECOMMEND TWO CIRCUITS
A-ONE FOR LETTERS
B-ONE FOR BORDER
IN CASE THEY WANT THOSE IN SEPARATE
SWITCHES

BUILDING COLORS

Designer Color Collection ⓘ Expert Pick
SW 9606
Slumber Sloth

Designer Color Collection ⓘ
SW 9607
Tanglewood

ACCENT

BODY

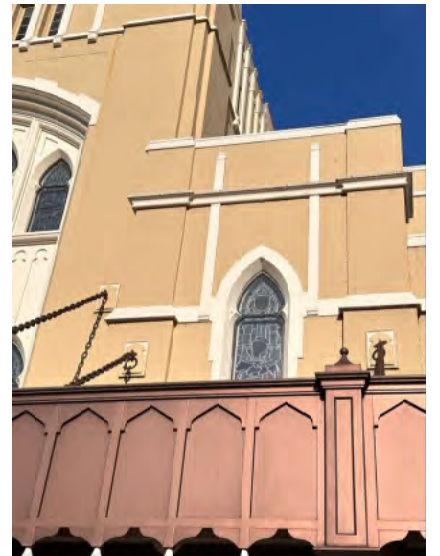

EXISTING



p 510 375 0263 www.duarteid.com
ELSINORE THEATRE Salem, OR
ENTRANCE MAY 28 24
ENTRANCE JUN 6 24
ENTRANCE SEPT 1 24

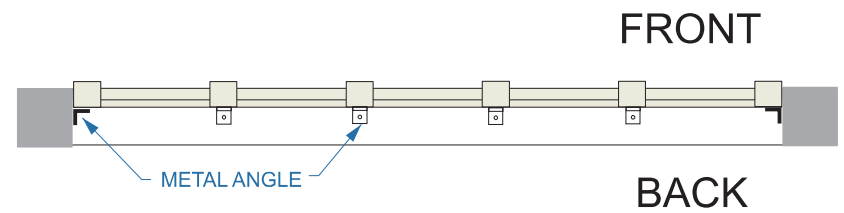

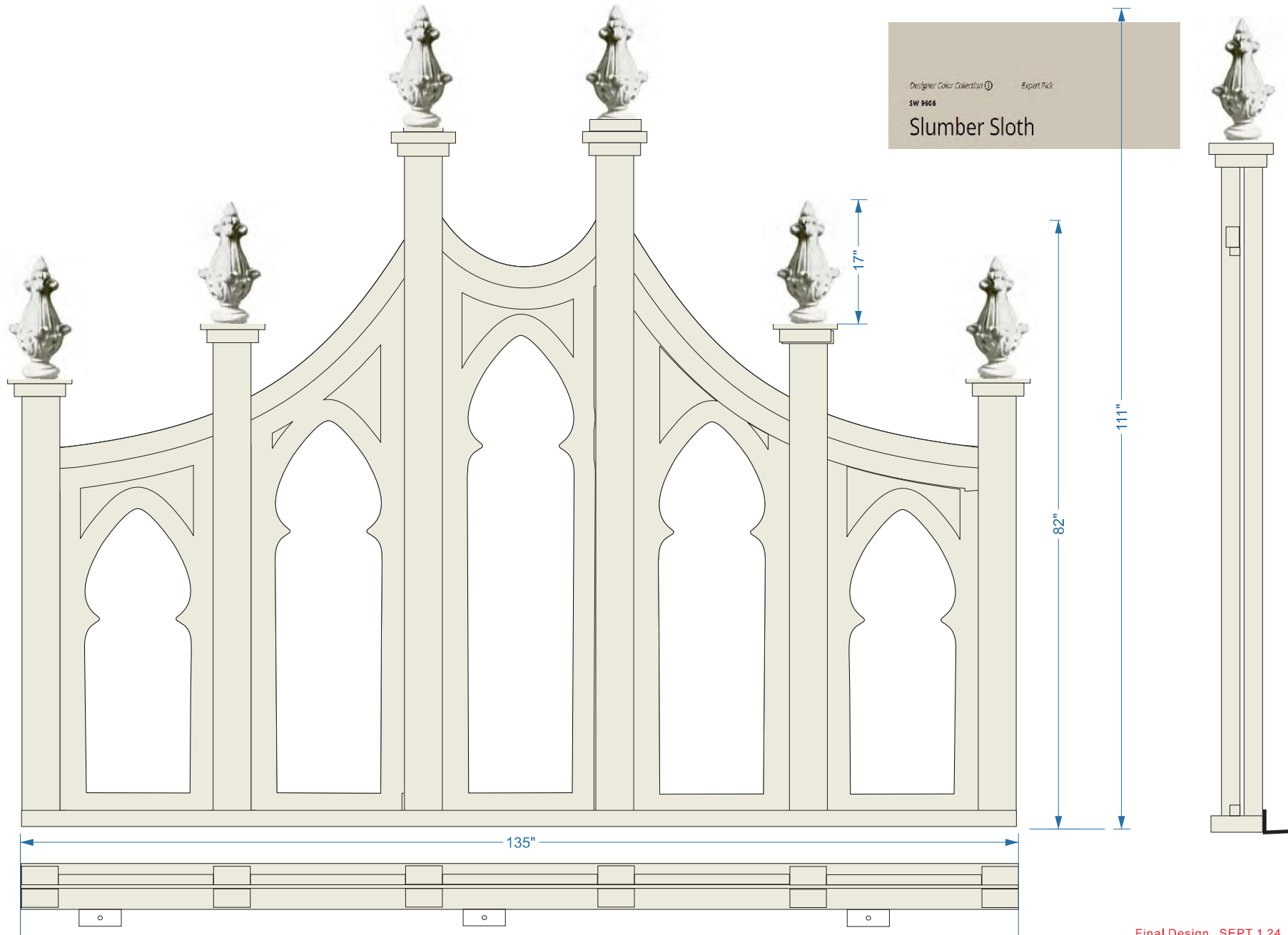

Designer Color Collection Expert Pick
 SW 9666
Slumber Sloth

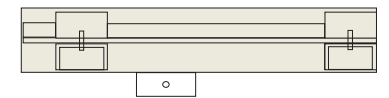
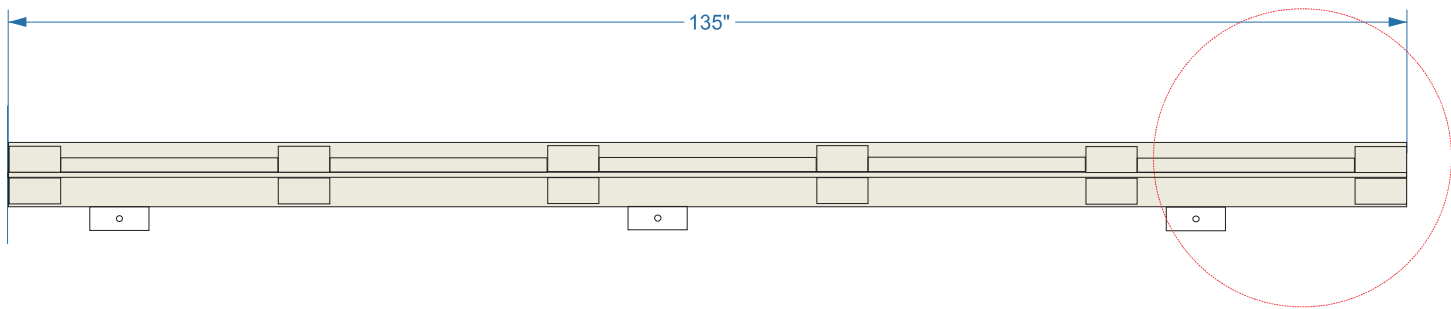

TOP STRUCTURES



(1) ONE FRONT STRUCTURE

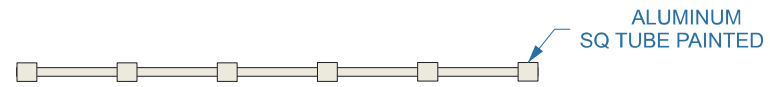
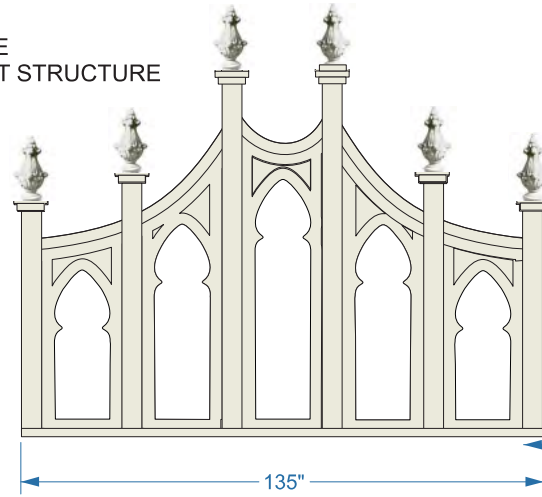

ALUMINUM SQ TUBE PAINTED

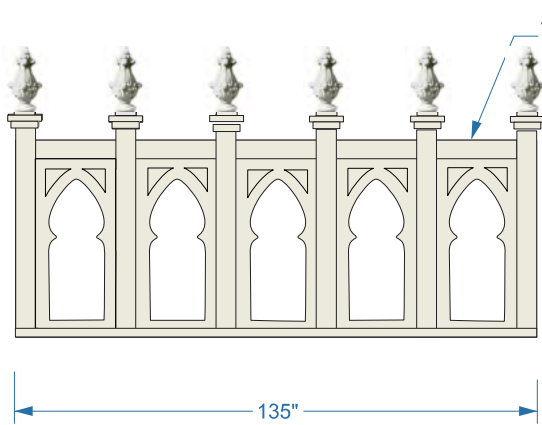

ALL ALUMINUM CONSTRUCTION

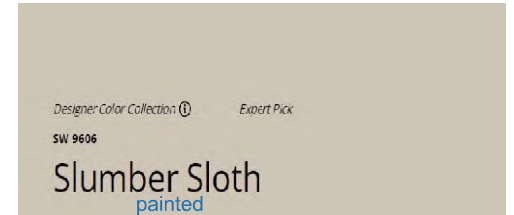

(2) TWO SIDE STRUCTURES

LED DISPLAYS

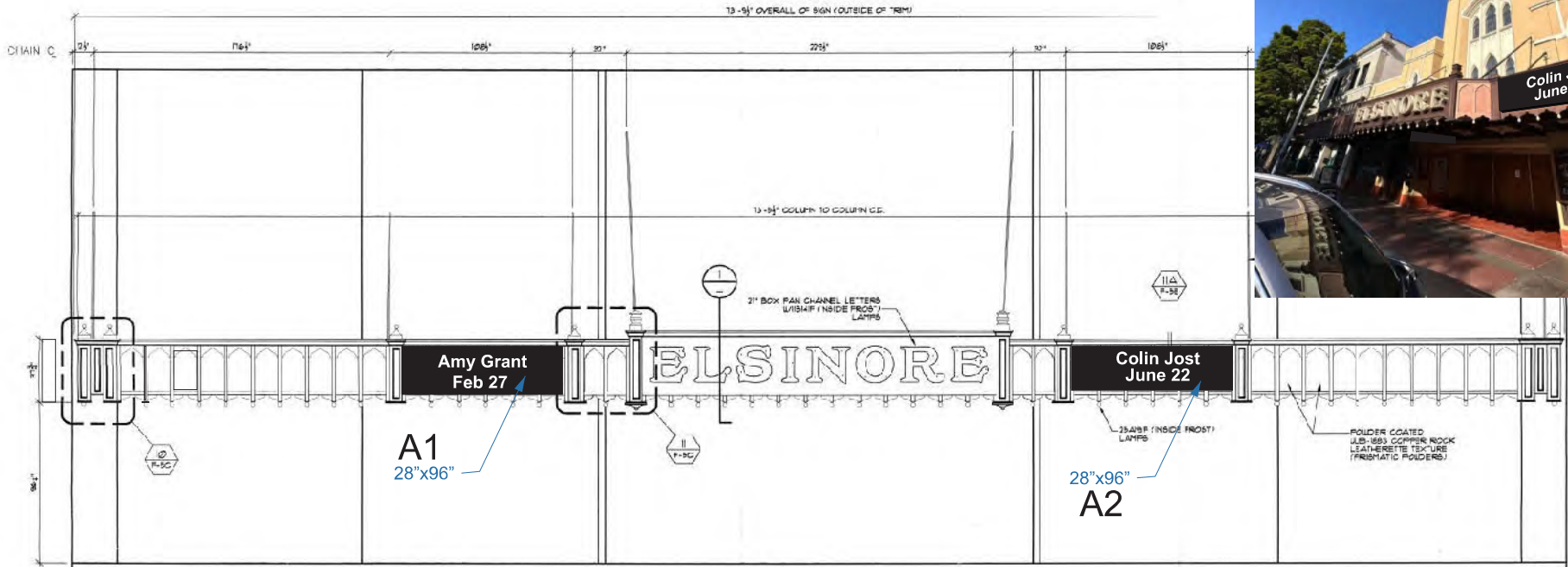
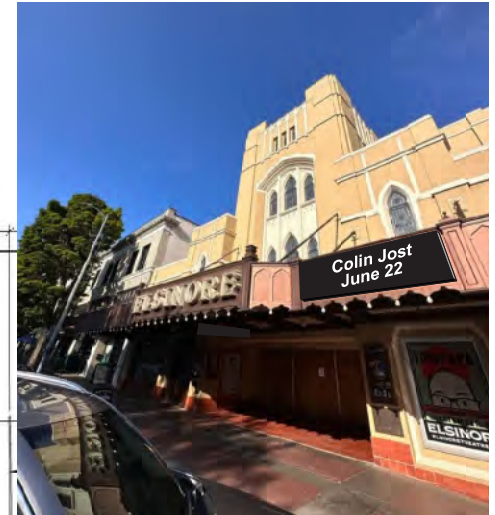

A3
28"x108"

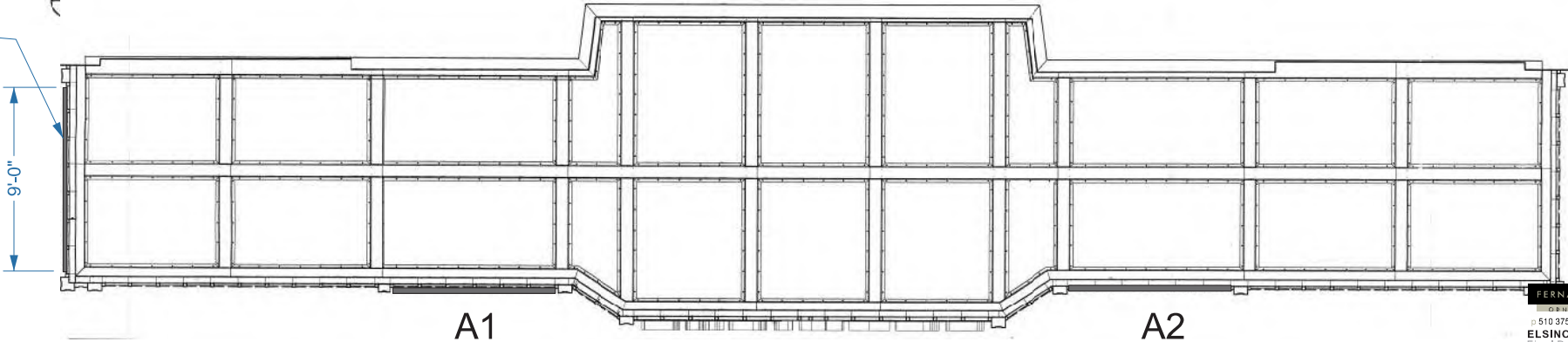

p 510 375 0263 www.duarteid.com
 Final Design Feb 20 24
 Final Design REV. APRIL 15 24
 Final Design REV. JUNE 14 24

Final Design SEPT 1 24

ELSINORE THEATRE Salem, OR

LED DISPLAYS

A1 28"x96" A2 28"x96"

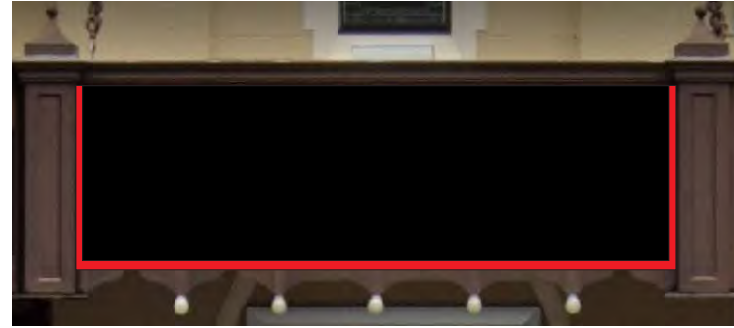
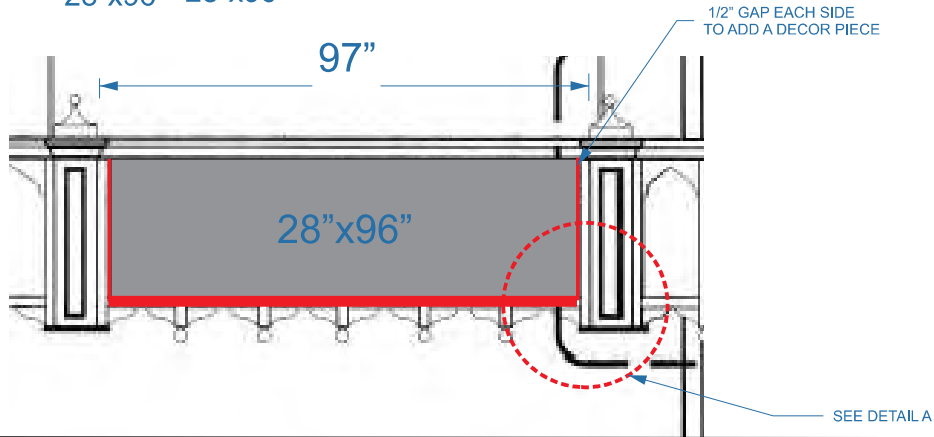

A3 28"x108"

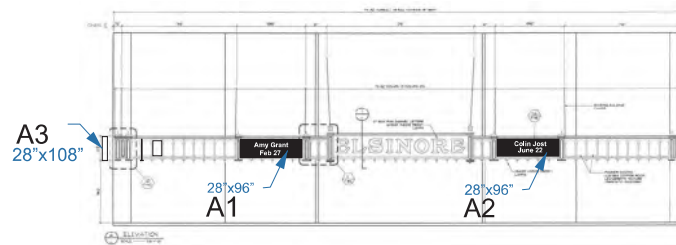
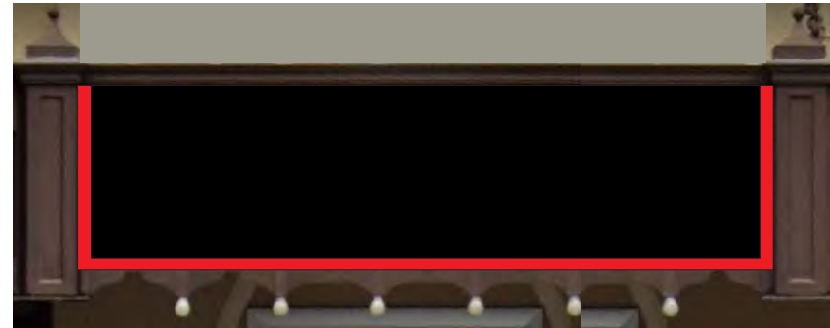
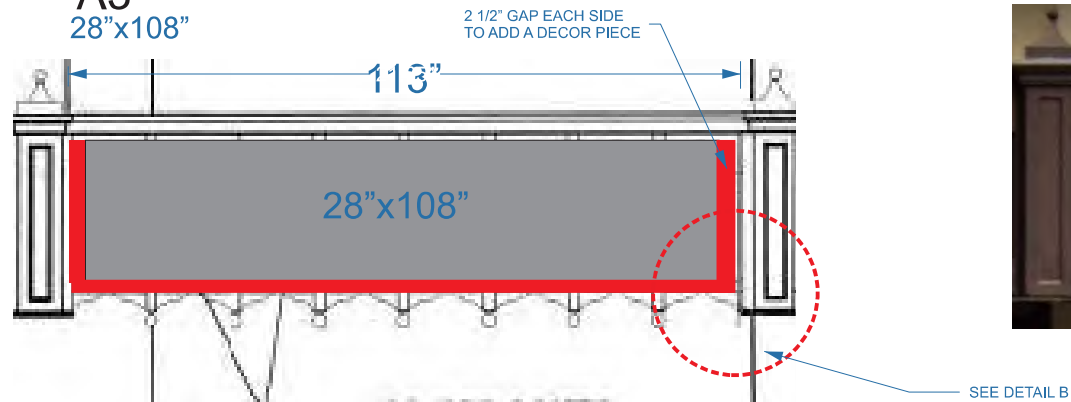

Final Design SEPT 1 24

LETTERS

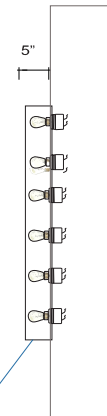
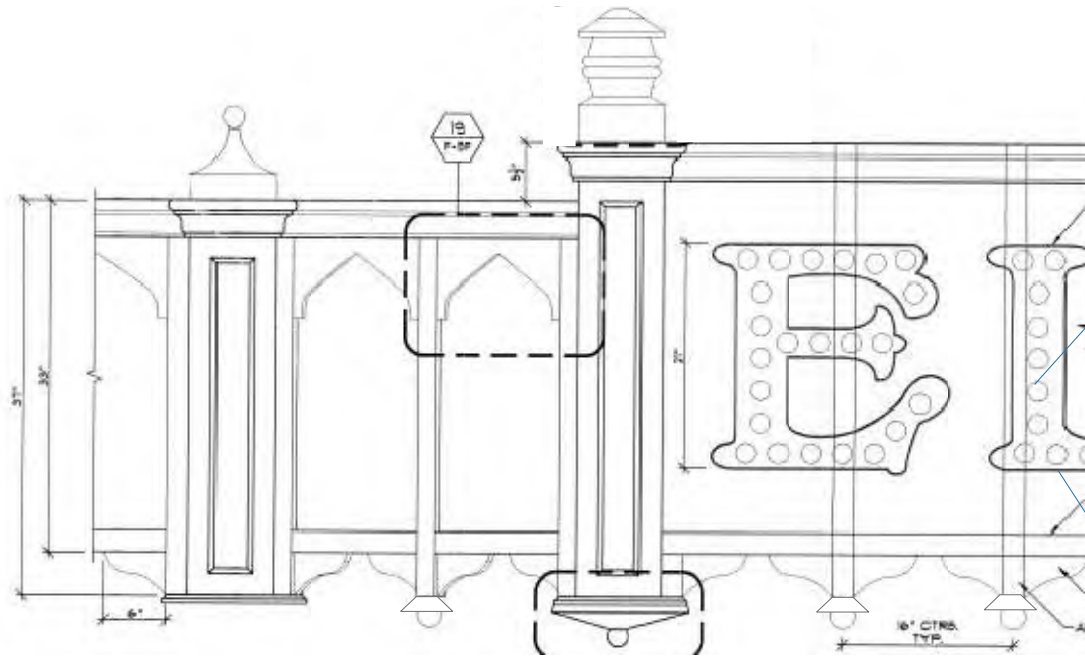
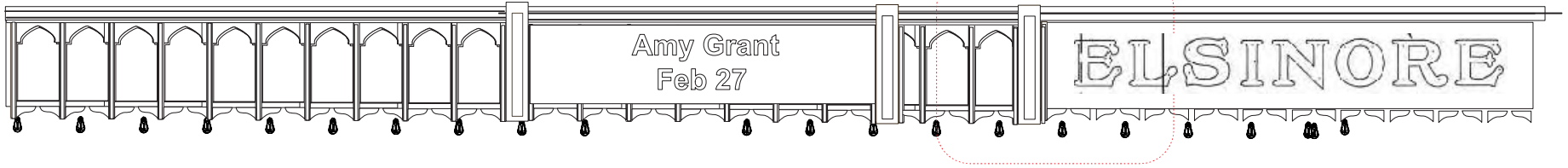

RESTORE EXISTING OPEN CHANNEL
LETTERS PAINTED INSIDE ANTIQUE WHITE
OUTSIDE GOLD
NEW SOCKETS AND NEW LED BULBS



SOFFIT

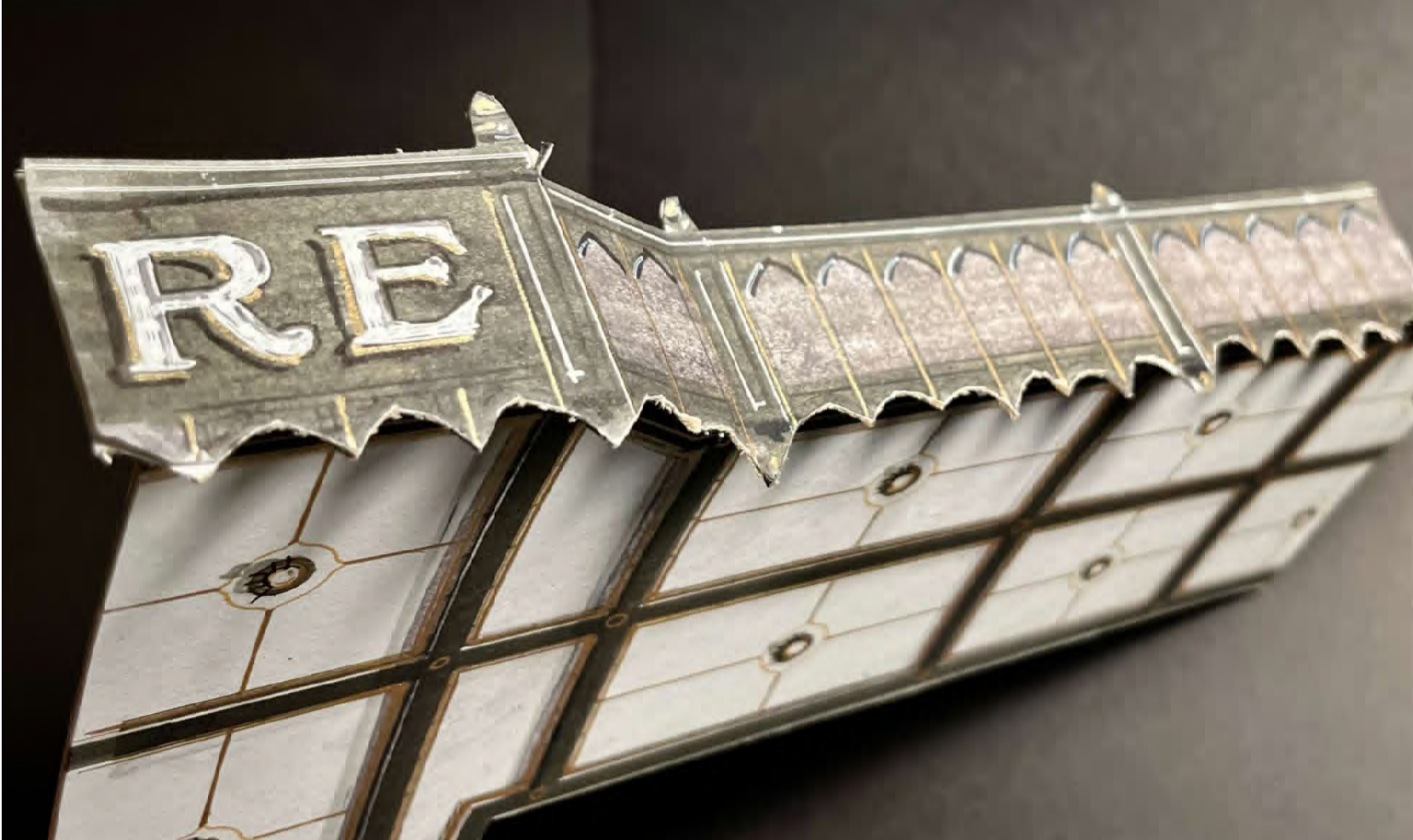

MARQUEE

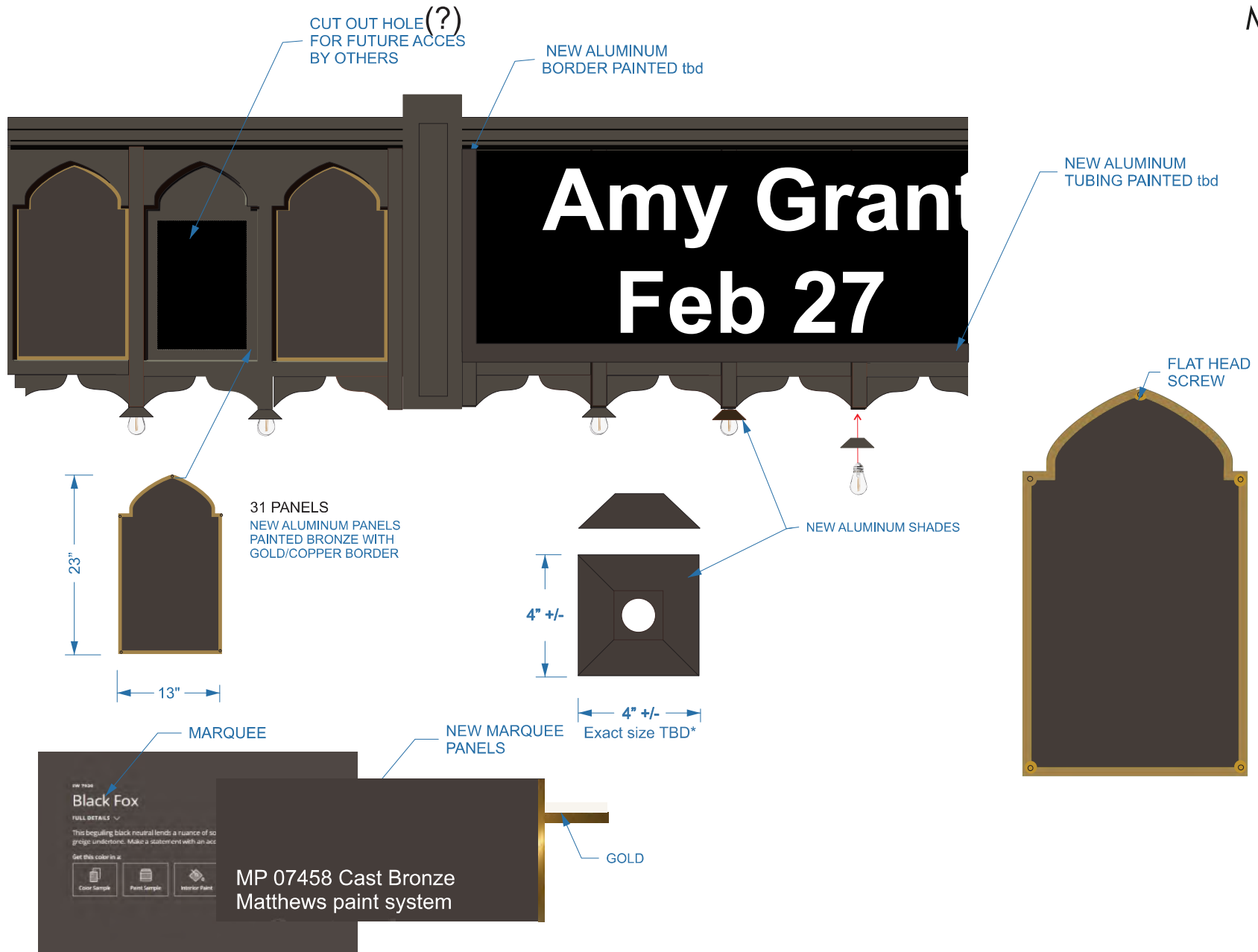

Designer Color Collection ① Expert Pick
SW 9606
Slumber Sloth

Designer Color Collection ①
SW 9607
Tanglewood

SW 7020
Black Fox
FULL DETAILS ▾
This beguiling black neutral lends a nuance of sophistication with its warm greige undertone. Make a statement with an accent wall or a well-lit office.
Get this color in a:
Color Sample Paint Sample Interior Paint Exterior Paint

MP 07458 Cast Bronze
Matthews paint system

GOLD



SOFFIT

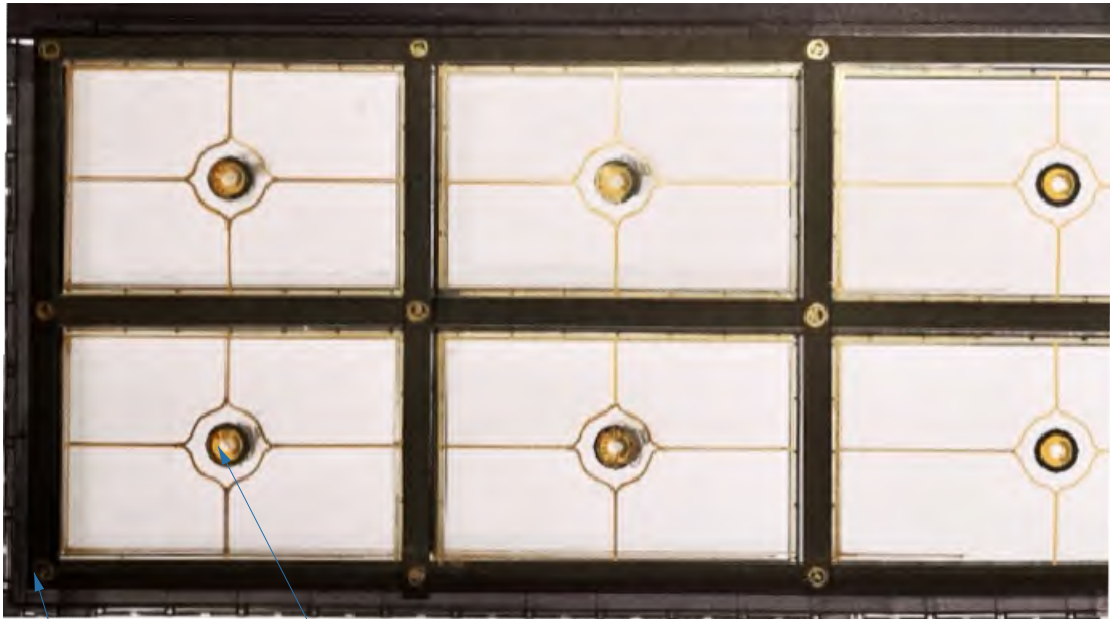

4" METAL ROSSETTE
PAINTED DK COPPER

SCHOOL HOUSE
LAMPS

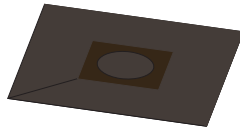

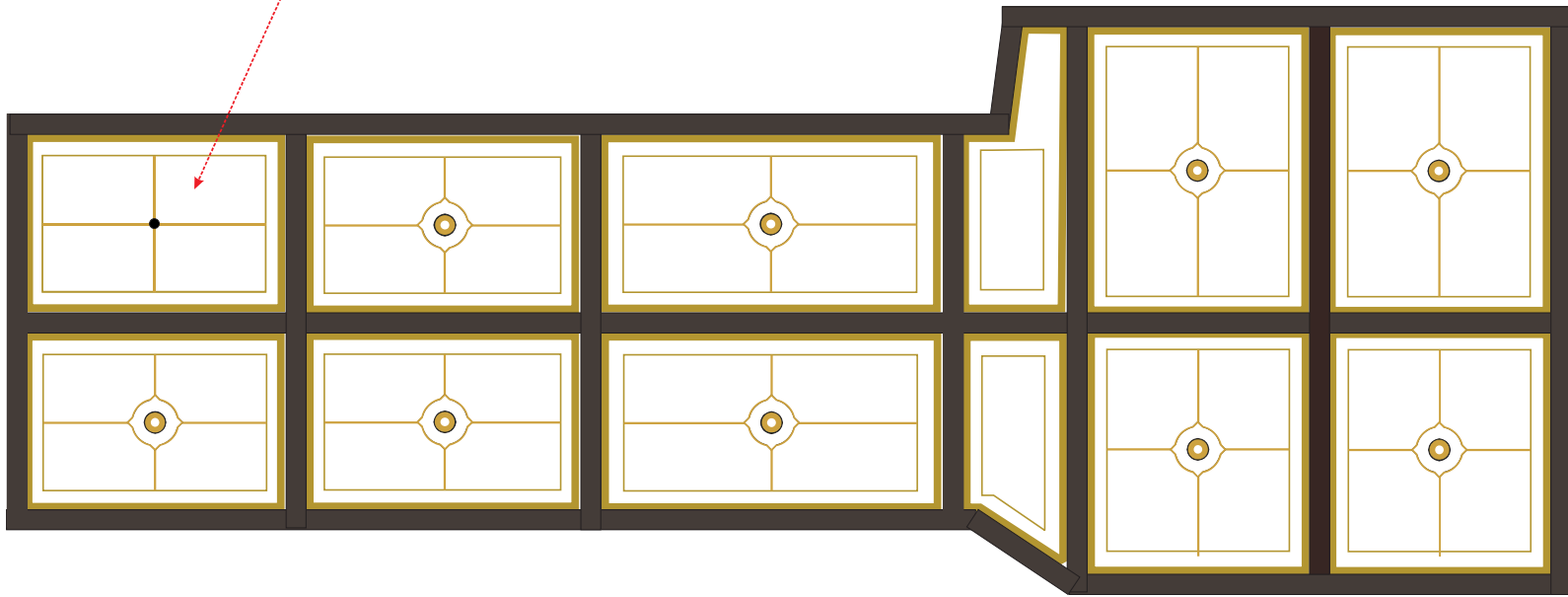
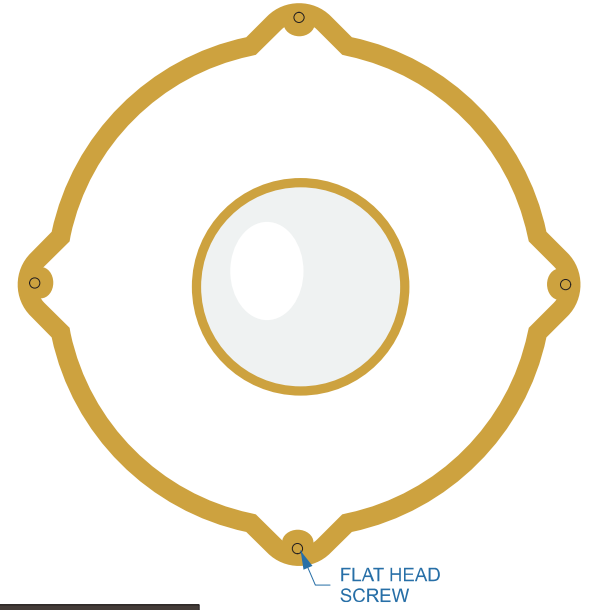
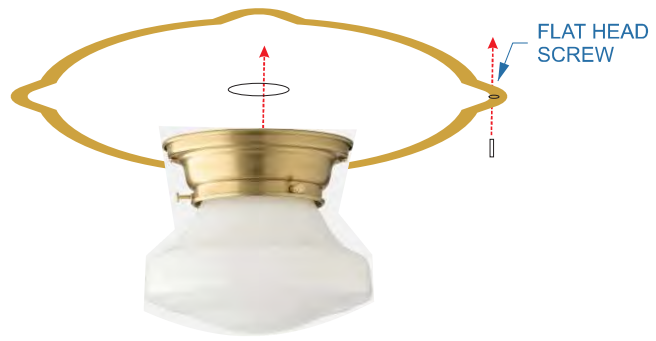
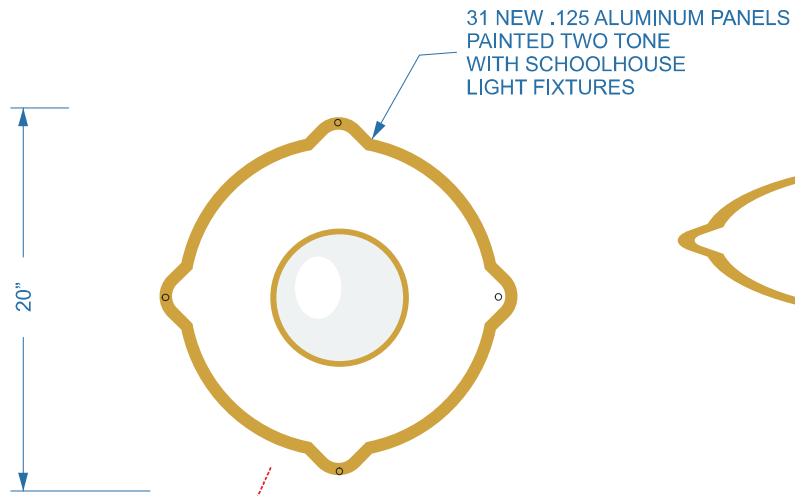

SCHOOL HOUSE
Otis 4" Surface Mount
BRASS FINISH

SOFFIT

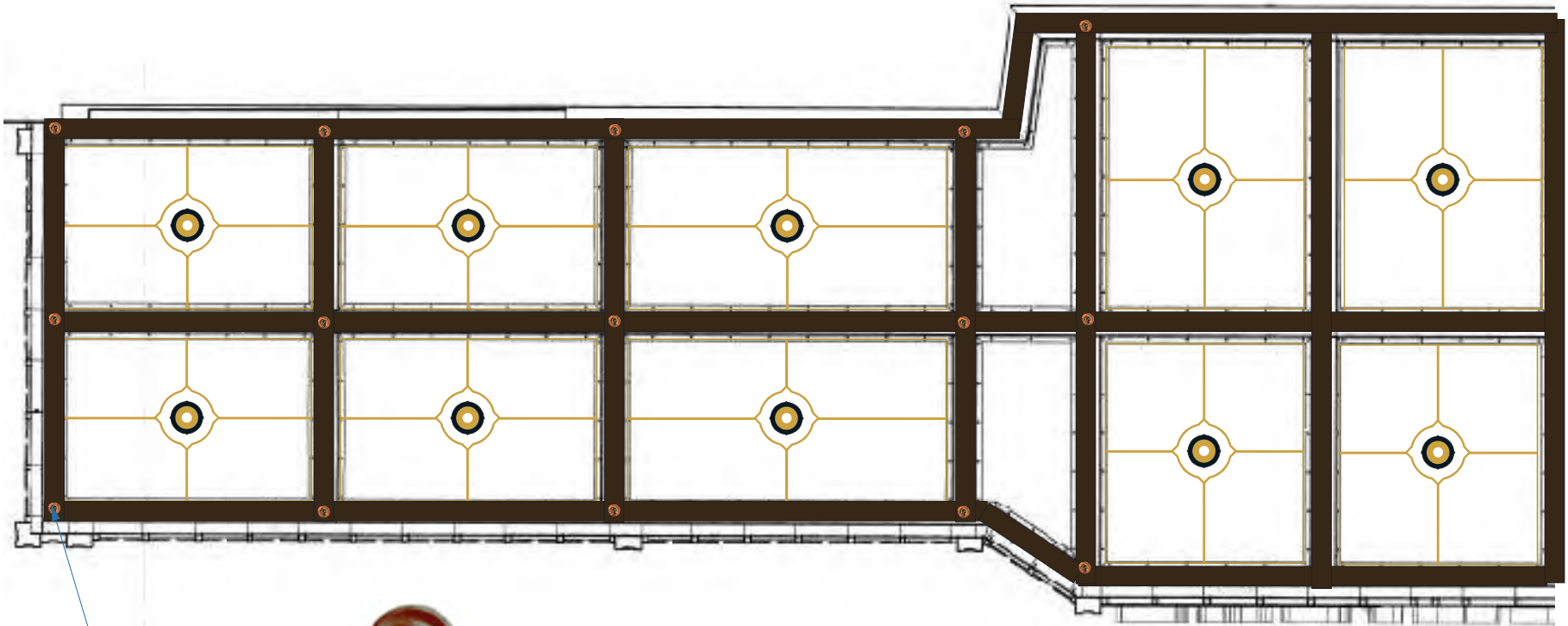
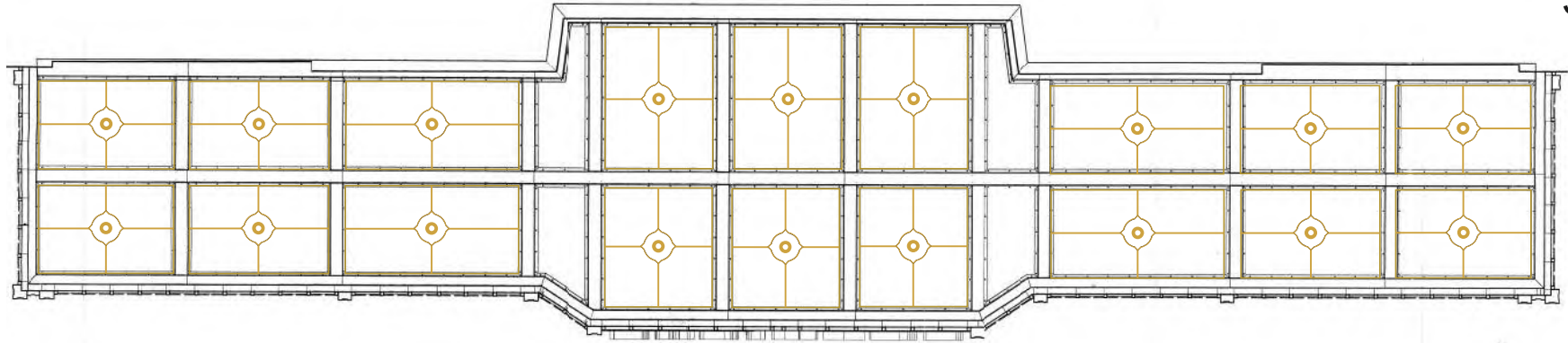

4" METAL ROSSETTE
PAINTED DK COPPER



SOFFIT

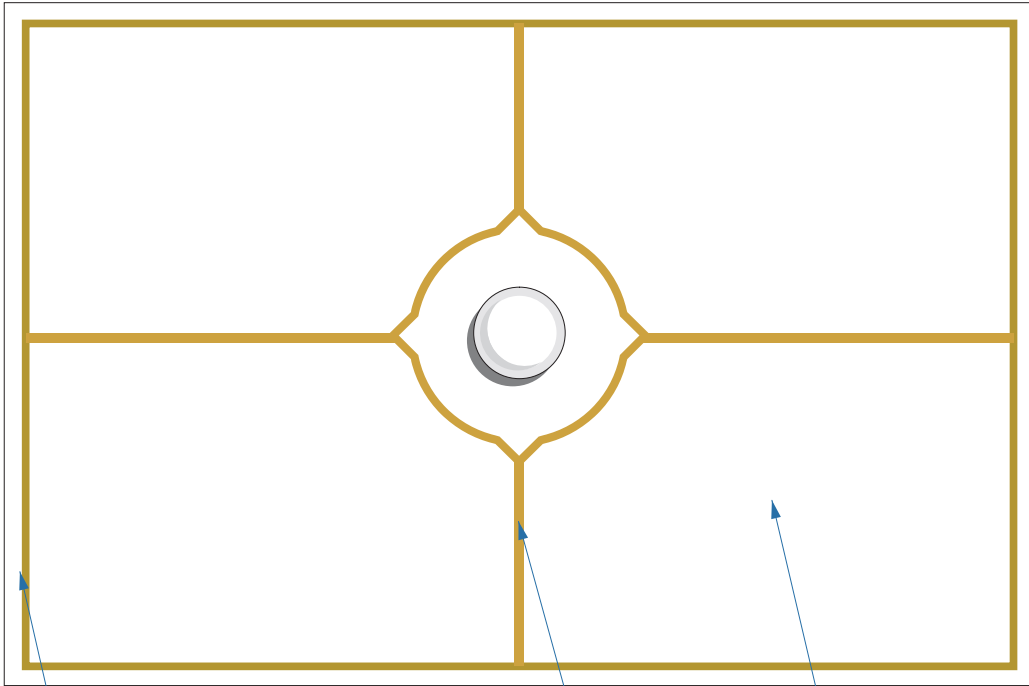

MOULDING PAINTED GOLD
BY OTHERS

NEW LINES PAINTED GOLD
BY OTHERS

EXISTING PANELS

NEW LINES
PAINTED GOLD
BY OTHERS

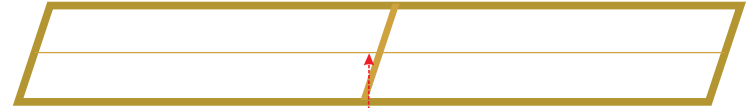

31 NEW .125 ALUMINUM PANELS
PAINTED TWO TONE
WITH SCHOOLHOUSE
LIGHT FIXTURES

SCHOOL HOUSE
Otis 4" Surface Mount
BRASS FINISH

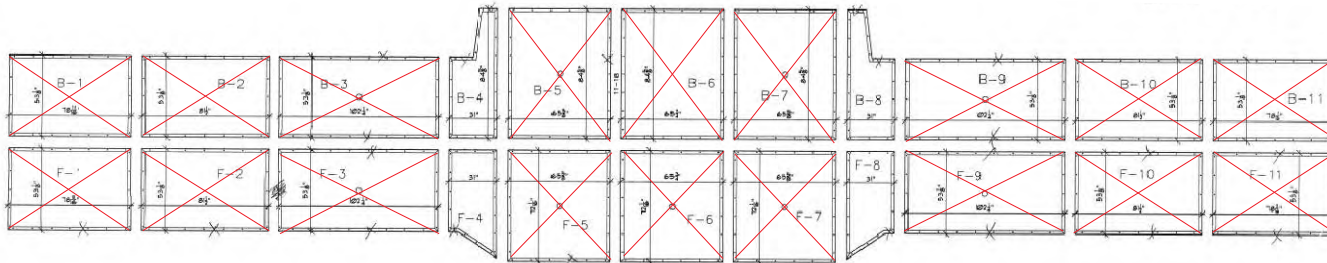

ENTRANCE ELEVATION



FERNANDO DUARTE DESIGN

ORNAMENTAL ARTS & DESIGN

p 510 375 0263 www.duarteid.com

ELSINORE THEATRE Salem, OR

ENTRANCE MAY 28 24

ENTRANCE JUN 6 24

ENTRANCE SEPT 1 24

ENTRANCE ELEVATION



DOORS AND HANDLES

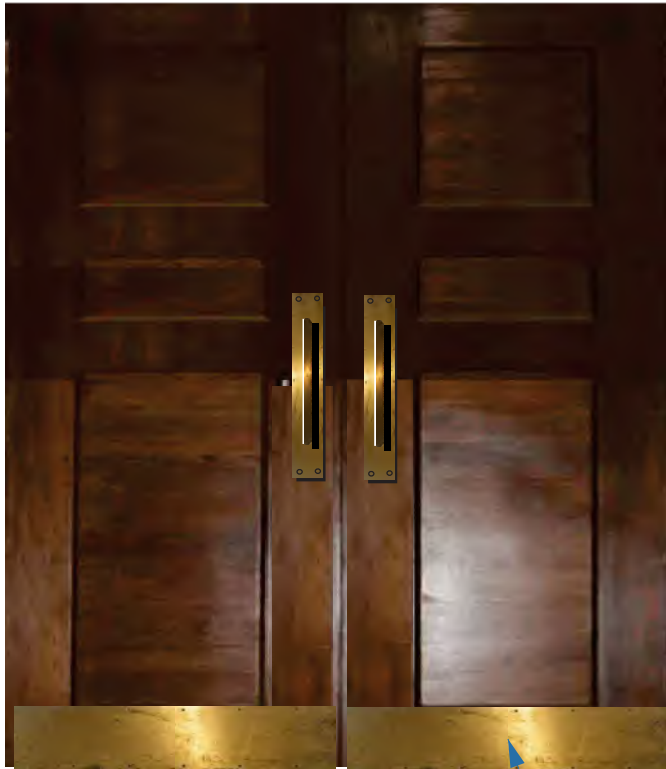

NEW KICK PLATE

ENTRANCE FLOOR



FERNANDO DUARTE DESIGN

ORNAMENTAL ARTS & DESIGN

p 510 375 0263 www.duarteid.com

ELSINORE THEATRE Salem, OR

ENTRANCE MAY 28 24

ENTRANCE JUN 6 24

ENTRANCE SEPT 1 24

ENTRANCE ELEVATION SIDE COLOR OPTIONS

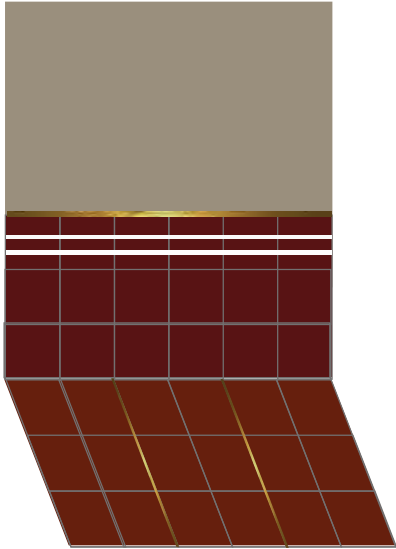
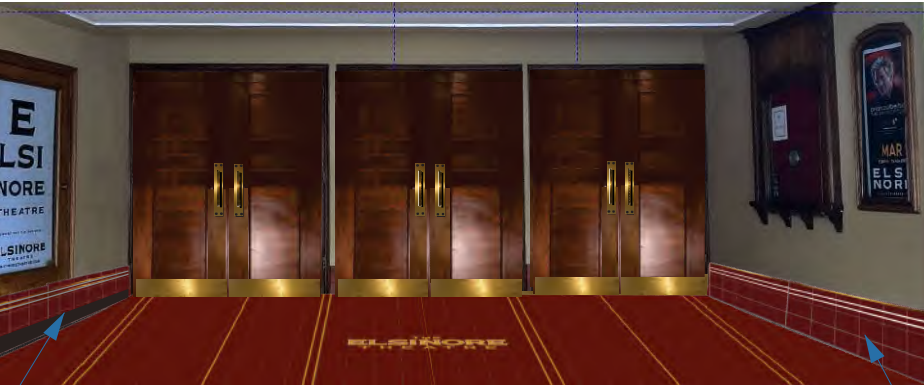
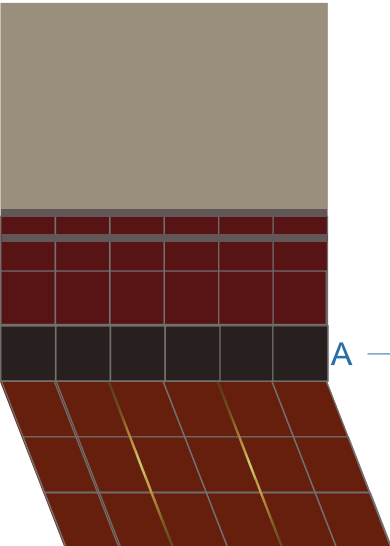

A

B

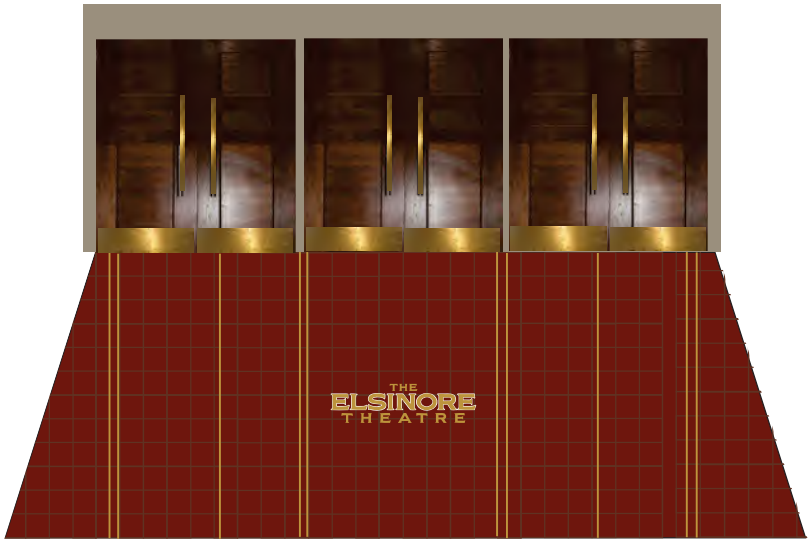

p 510 375 0263 www.duarteid.com
EL SINORE THEATRE Salem, OR
ENTRANCE MAY 28 24
ENTRANCE JUN 6 24
ENTRANCE SEPT 1 24

POSTER WALL

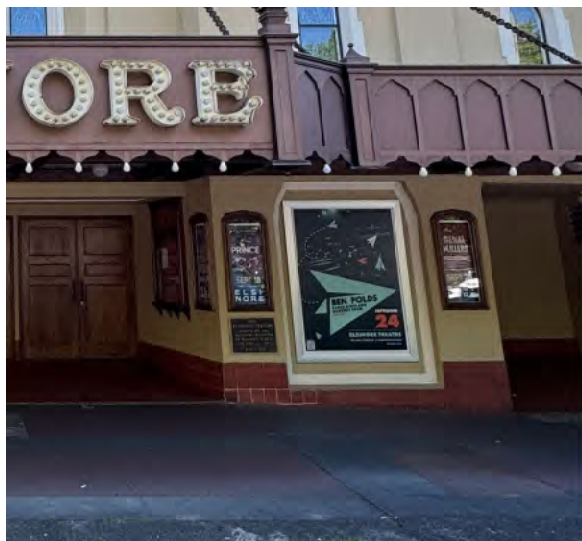

p 510 375 0263 www.duarteid.com
EL SINORE THEATRE Salem, OR
ENTRANCE MAY 28 24
ENTRANCE JUN 6 24
ENTRANCE SEPT 1 24

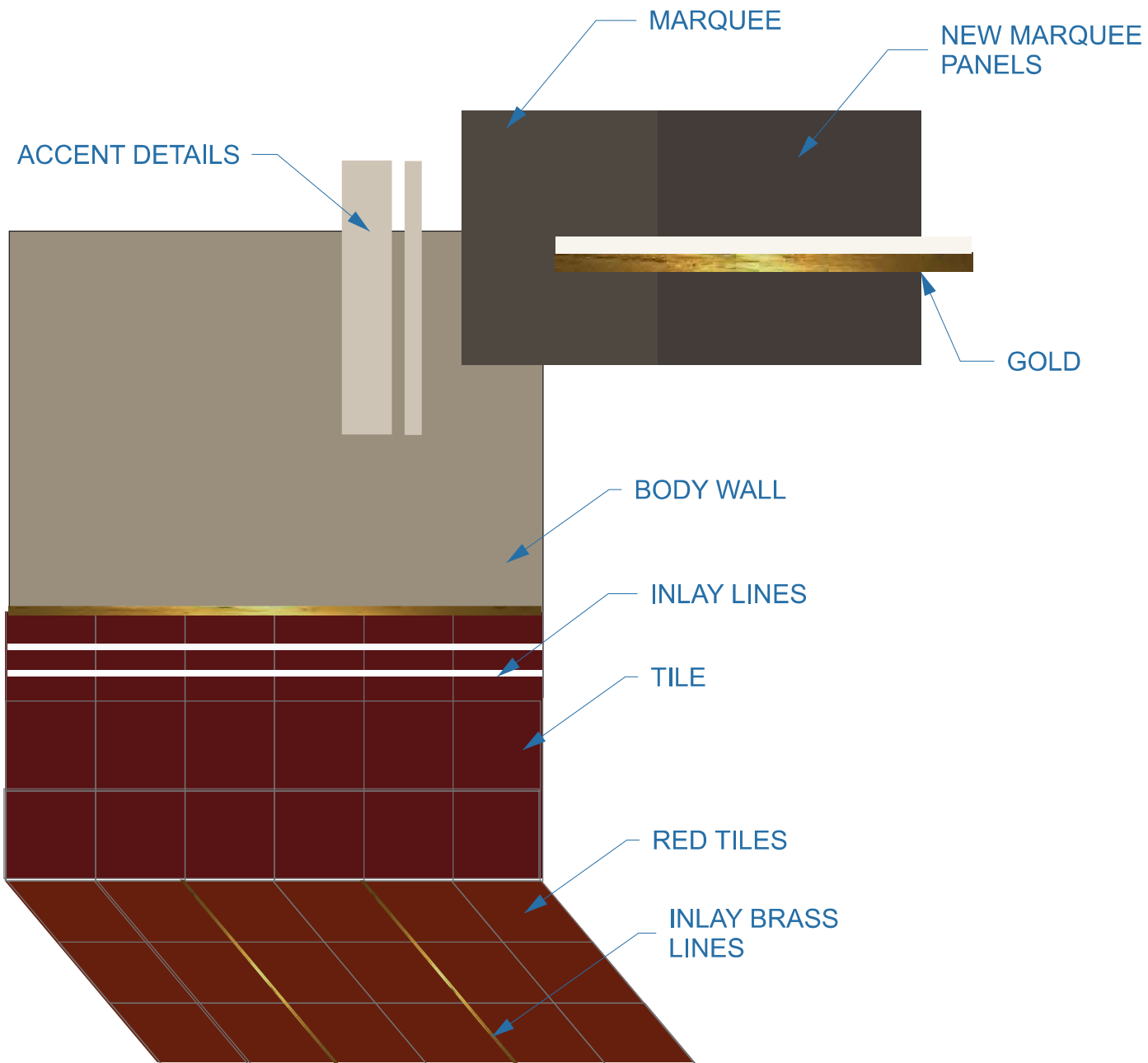

ATTACHMENT D

Jake Morris

From: Laurel Christian
Sent: Friday, September 27, 2024 8:34 AM
To: Jake Morris
Cc: Kimberli Fitzgerald; Tony Martin; Zachery Cardoso
Subject: RE: Request for Comments - Case No. HIS24-19 for 170 High St SE

Good morning, Jake,

Development Services would like to submit the following comments for Case No. HIS24-19 for 170 High St SE:

Encroachments into the public right-of-way are not permitted without a Revocable License to Encroach into the right-of-way issued by the Public Works Director (SRC 76.160) . From the information provided, it appears the sign will project into the right-of-way of High Street NE; however, is unclear from the information provided how far the proposed sign will project. The sign will not be permitted to extend past the existing canopy that covers the sidewalks along High Street NE; a detailed site plan will be required at time of Building Permit. We recommend that the application be conditioned to obtain any necessary structural Building Permits to ensure that the sign is structurally sound and does not pose a risk to the public right-of-way. In addition, we recommend that a condition of approval be established to ensure the applicant obtain a Revocable License to Encroach prior to issuance of a Building Permit for this sign.

Thank you,

Laurel Christian

Infrastructure Planner III

City of Salem | Community Planning and Development | Development Services

555 Liberty St SE, Suite 320, Salem OR 97301-3515

lchristian@cityofsalem.net | Office: 503-584-4632

[Facebook](#) | [YouTube](#) | [LinkedIn](#) | www.cityofsalem.net

From: Zachery Cardoso <ZCardoso@cityofsalem.net>
Sent: Wednesday, September 25, 2024 10:56 AM
To: Zachery Cardoso <ZCardoso@cityofsalem.net>
Cc: Jake Morris <jjmorris@cityofsalem.net>; Kimberli Fitzgerald <KFitzgerald@cityofsalem.net>
Subject: Request for Comments - Case No. HIS24-19 for 170 High St SE

Hello,

The Request for Comments for Historic Design Review Case No. HIS24-19 for 170 High St SE is attached for your information. Comments are due **Wednesday, October 9, 2024 by 5:00 p.m.** Hard copies go out in the mail today for those of you who are to receive one.

Application Summary: A proposal to install a reconstruction of the historic “ELSINORE” blade sign c.1928 and restore aspects of the marquee and entrance area.

Please direct questions or comments to the **CASE MANAGER:**

Jake Morris

jjmorris@cityofsalem.net

503-540-2417

Thank you,

Zachery Cardoso

[he/they](#)

Admin Analyst I

City of Salem | Community Planning and Development Department | Planning

555 Liberty St SE, Suite 305

Salem OR 97301

zcardoso@cityofsalem.net | 503-540-2304

[Facebook](#) | [Twitter](#) | [YouTube](#) | CityofSalem.net

Jake Morris

From: MICHAEL LIVINGSTON <michaellivingston1@msn.com>
Sent: Wednesday, September 25, 2024 4:35 PM
To: Zachery Cardoso
Cc: Jake Morris; Kimberli Fitzgerald; Owens, Sarah; M Baird; Irma Coleman
Subject: Re: Request for Comments - Case No. HIS24-19 for 170 High St SE

Zachery,

On behalf of CANDO, I am submitting this comment in response to your request below in Historic Design Review Case No. HIS24-19 for 170 High St SE:

Based on the materials provided, CANDO supports the applicant's proposal to install a reconstruction of the historic "ELSINORE" blade sign c.1928 and restore aspects of the marquee and entrance area. The proposed project will restore and enhance the historic character of this building.

Michael Livingston
CANDO Chair
michaellivingston1@msn.com

From: Zachery Cardoso <ZCardoso@cityofsalem.net>
Sent: Wednesday, September 25, 2024 10:55 AM
To: Zachery Cardoso <ZCardoso@cityofsalem.net>
Cc: Jake Morris <jjmorris@cityofsalem.net>; Kimberli Fitzgerald <KFitzgerald@cityofsalem.net>
Subject: Request for Comments - Case No. HIS24-19 for 170 High St SE

Hello,

The Request for Comments for Historic Design Review Case No. HIS24-19 for 170 High St SE is attached for your information. Comments are due **Wednesday, October 9, 2024 by 5:00 p.m.** Hard copies go out in the mail today for those of you who are to receive one.

Jake Morris

From: Kara Kuh <Kara@travelsalem.com>
Sent: Friday, October 4, 2024 9:57 AM
To: Jake Morris
Subject: Testimony in Favor of Elsinore Theatre's Request
Attachments: ElsinoreTheatreSupportTS.pdf

Hello, the attached letter is in support of the Elsinore Theatre's request (Class 3 Major Historic Design Review Case No. HIS24-19).

Thank you.



kara

KUH

chief marketing officer
(aka builder of buzz)

630 Center St. NE,
Salem, Oregon 97301
office: 503.581.4325 x124
Kara@TravelSalem.com
TravelSalem.com





October 2, 2024

Salem Historic Landmarks Commission

To Whom It May Concern:

Please consider this letter in support of the funding request submitted by Elsinore Theatre for digital reader boards on their marquee. Travel Salem is proud to promote the Elsinore Theatre in their efforts to preserve this 1926 unique venue that serves both residents and visitors.

The digital reader board designed to look like a historic sign is an innovative way for the Elsinore to use technology with a historic visual element that's in keeping with the aesthetic of the building and neighborhood. The reader boards demonstrate an appropriate way for new technology and historic structures to work together and create a dynamic venue.

Salem is privileged to have the Elsinore Theatre as a cornerstone of cultural and historical significance for residents and visitors. The theatre plays a vital role in attracting people to Salem, offering insight into the rich culture and heritage of the area.

The Elsinore Theatre has demonstrated a strong commitment to projects that enhance residents' quality of life and serves as a key attraction for visitors in the Salem area.

We recommend a favorable decision to support the Elsinore Theatre's request.

Sincerely,

Kara Kuh
Chief Marketing Officer
kara@TravelSalem.com