

# NOTICE OF DECISION

*Si necesita ayuda para comprender esta informacion, por favor llame (503) 588-6173*

## ADMINISTRATIVE DECISION – MINOR HISTORIC REVIEW

**CASE NO.:** Historic Review Case HIS14-21MOD1 / AMANDA No. 16-101956-DR

**DECISION DATE:** February 2, 2016

**REQUEST:** Minor administrative historic design review to modify the administrative decision (HIS14-21MOD) approving installation of 6 "Art Wells" at sidewalk corner locations, to 7 "Art Wells" at sidewalk corner locations within the Downtown Salem Historic District, on properties zoned CB (Central Business District). The applicant does not propose any changes to the design of the Art Wells, each of which would consist of a 6 by 6 square foot opening in the sidewalk covered by a cast iron grate, similar to the approved tree well design.

**APPLICANT:** City of Salem, Public Works Department

**CONTACT:** Christina Vinson, for City of Salem Public Works Department

**LOCATION:** Various sites within the Salem Downtown Historic District

**CRITERIA:** Salem Revised Code (SRC) Chapter 230

**FINDINGS:** The applicant requests to modify the November 4, 2014 decision by the Urban Planning Administrator (HIS14-21MOD / AMANDA No. 14-117245-DR) to approve installation of "Art Wells" at 6 sidewalk corner locations within the Downtown Salem Historic District. In the modified proposal, the applicant proposes a total of 7 sidewalk corner locations within the Historic District.

In HIS14-21, and HIS 14-21MOD, staff reviewed the proposal for art wells for compliance with the standards for streetscape improvements in commercial historic districts as provided in SRC 230.075(a) and (b). Staff found that the decorative pattern of the cast iron grating is compatible with the character of the streetscape within the historic district, and that no significant historic sidewalk features that contribute to the Downtown Historic District would be disturbed by the installation of the proposed art wells. The applicant has not proposed any changes to the design of the art wells or the method of installation. Additionally, Public Works staff have found that the proposed new art well location meets applicable Public Works standards. Staff has reviewed the request for modification and finds that the new proposed locations for art wells would not affect compliance with the standards of SRC 230.075.

**DECISION:** Based upon the application materials deemed complete on January 29, 2016, and the findings as presented in this report, the application is APPROVED.

PLANNING DIVISION  
555 LIBERTY ST. SE, RM 305  
SALEM, OREGON 97301  
PHONE: 503-588-6173  
FAX: 503-588-6005

CITY OF Salem  
AT YOUR SERVICE



Kimberli Fitzgerald, AICP, Historic Preservation Officer  
Planning Administrator Designee

[kfitzgerald@cityofsalem.net](mailto:kfitzgerald@cityofsalem.net), Phone: (503) 540-2397

This Decision becomes effective on **February 18, 2016**. No work associated with this Decision shall start prior to this date unless expressly authorized by a separate permit, land use decision, or provision of the Salem Revised Code (SRC).

Application Deemed Complete: January 29, 2016  
Notice of Decision Mailing Date: February 2, 2016  
Decision Effective Date: February 18, 2016  
State Mandated Decision Date: May 28, 2016

The rights granted by this decision must be exercised by February 18, 2018, or this approval shall be null and void.





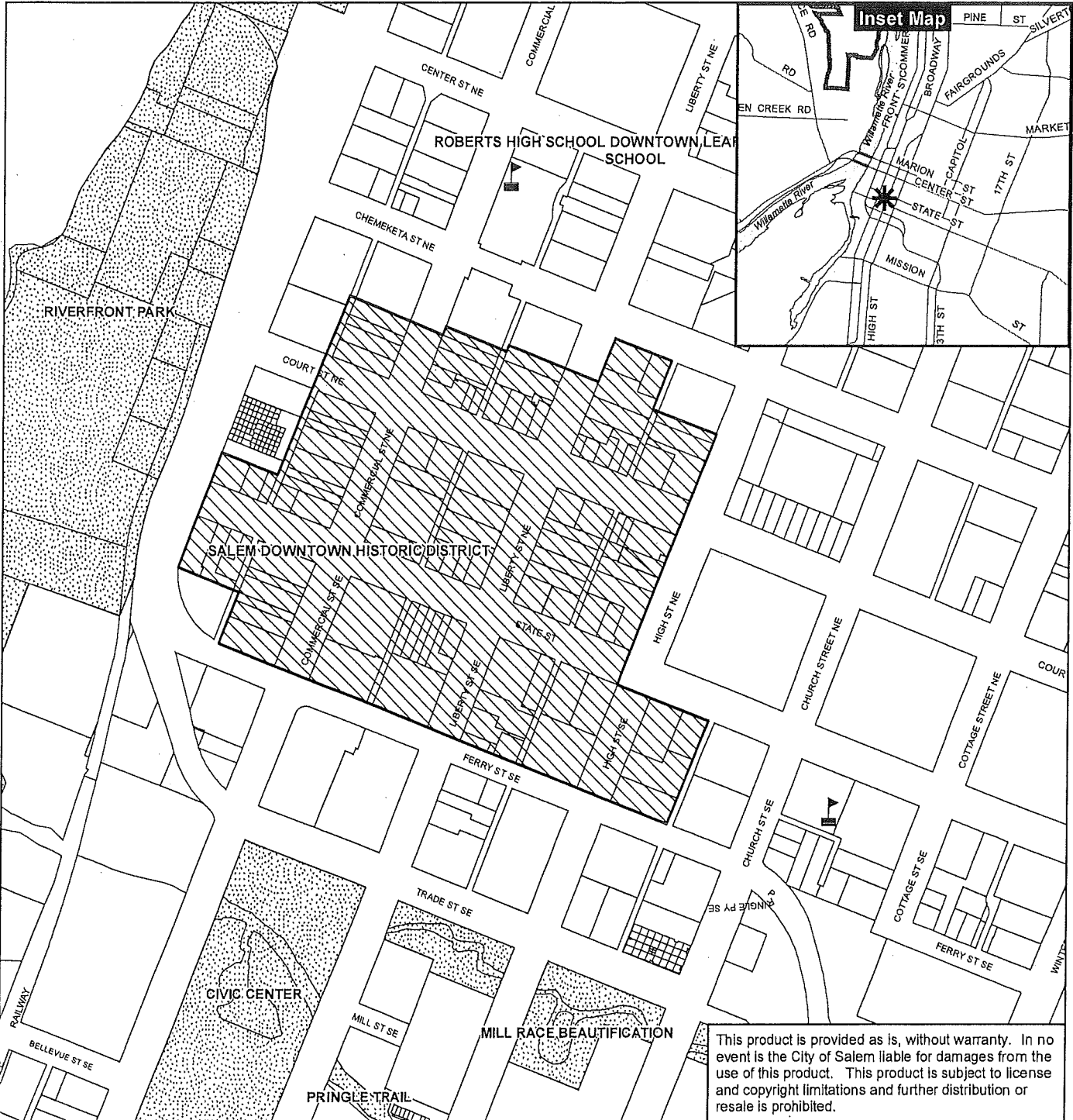

This decision is final unless written appeal from an aggrieved party is filed with the City of Salem Planning Division, Room 305, 555 Liberty Street SE, Salem, OR 97301, no later than **5:00 p.m., February 17, 2016**. The appeal must state where the decision failed to conform to the provisions of the historic preservation ordinance (SRC Chapter 230). The appeal must be filed in duplicate with the City of Salem Planning Division. The appeal fee must be paid at the time of filing. If the appeal is untimely and/or lacks the proper fee, the appeal will be rejected. The Salem Historic Landmarks Commission will review the appeal at a public hearing. After the hearing, the Historic Landmarks Commission may amend, rescind, or affirm the action, or refer the matter to staff for additional information.

# Vicinity Map SALEM DOWNTOWN HISTORIC DISTRICT



This product is provided as is, without warranty. In no event is the City of Salem liable for damages from the use of this product. This product is subject to license and copyright limitations and further distribution or resale is prohibited.

### Legend

-  Outside Salem City Limits
-  Historic District
-  Urban Growth Boundary
-  Schools
-  Taxlots
-  Parks



0 100 200 400 Feet





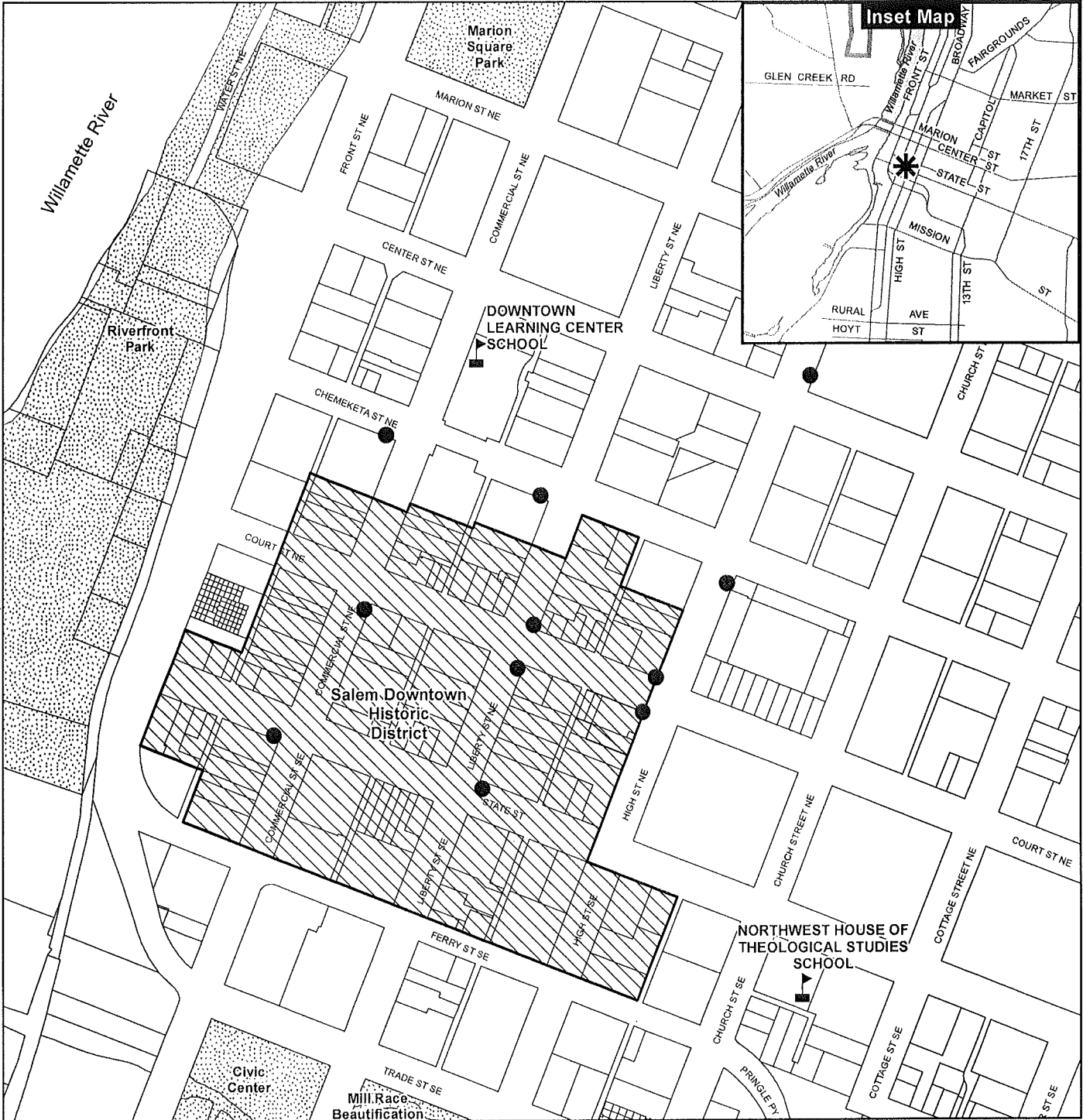

CITY OF *Salem*  
AT YOUR SERVICE  
Community Development Dept.

# Downtown Art Well Locations

## Salem Public Art Commission



### Legend





-  Taxlots
-  Urban Growth Boundary
-  City Limits
-  Parks
-  Historic District
-  Schools
-  Art Well Location



This product is provided as is, without warranty. In no event is the City of Salem liable for damages from the use of this product. This product is subject to license and copyright limitations and further distribution or resale is prohibited.

# Salem Downtown Historic District

## Map Legend

-  Historic Contributing
-  Historic Non-Contributing
-  Non-Historic / Non-Contributing
-  Parking
-  Vacant

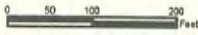

*Salem*  
COMMUNITY  
DEVELOPMENT  
GIS

CHEMEKETA ST

COURT ST  
*new*

STATE ST

FRONT ST

COMMERCIAL ST

LIBERTY ST

HIGH ST

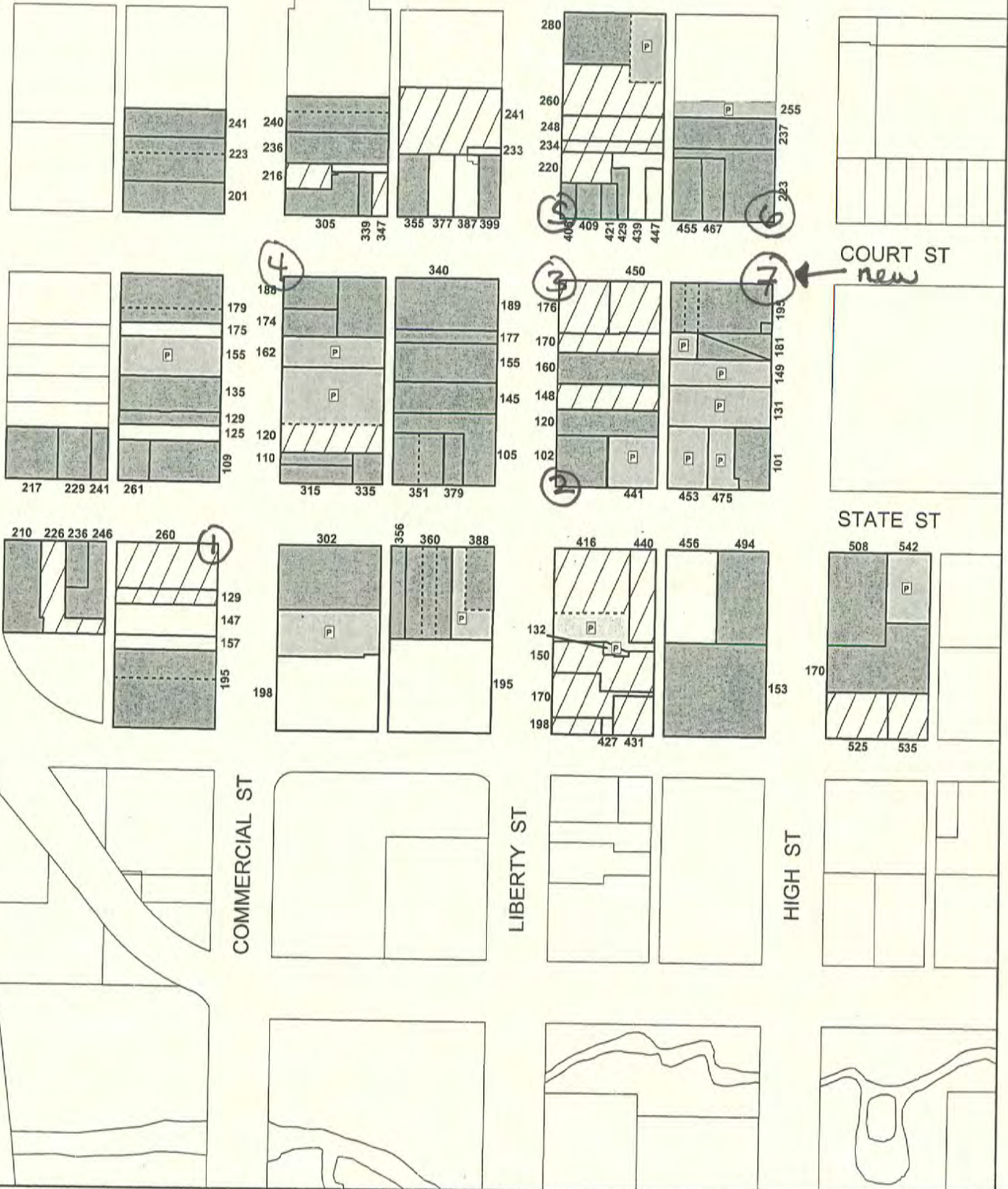

# Downtown Streetscape



© 2018 Metropolitan Council, Project 2018-01-01, Project 2018-01-01, Project 2018-01-01



FOR REVIEW

**GRATE NOTES**

1. OUTER GRATE - IRONSMITH TREE GRATE OLYMPIAN MODEL 7204 - 72" SQUARE, IN TWO SECTIONS, WITH 36.75" CENTER HOLE, and 2 ROUND LIGHTWELLS WITH BOLTED COVERS, UNFINISHED.
2. INNER GRATE - IRONSMITH TREE GRATE OLYMPIAN MODEL 3603 - 36" ROUND, IN TWO SECTIONS, WITH NO CENTER HOLE, UNFINISHED. INNER GRATE THICKNESS MODIFIED TO EQUAL THICKNESS OF OUTER GRATE. INNER GRATE IS BOLTED TO ARTWORK SUPPORT STRUCTURE. SEE STND PLAN 8XY.
3. SLOT WIDTH IS 1/4" MAXIMUM, MEETS ADA COMPLIANCE.
4. GRATE FROM GREY CAST IRON. STEEL ANGLE FRAME REQUIRED. SEE GRATE FRAME DETAILS..
5. OUTER GRATE CENTER HOLE 3/4" LARGER THAN INNER GRATE OUTSIDE DIMENSION.
6. IF USED, 2 CORNER LIGHTS, IRONSMITH MODEL TGL-5DF, WITH SHIELD AND 5 WATT 5000K DAYLIGHT OptILED L.E.D. MR16 40 DEGREE SPREAD LAMPS.
7. IF CORNER LIGHTS USED, NEED IRONSMITH ELECTRONIC TRANSFORMER, MODEL TGL75T , 120V AC 75 VA WITH 11.6 V OUTPUT FOR 12V LAMPS.
8. POWER SOURCE IS PROJECT SPECIFIC. DESIGN AS NECESSARY TO MEET ELECTRICAL CODE AND PROVIDE GFI PROTECTION.

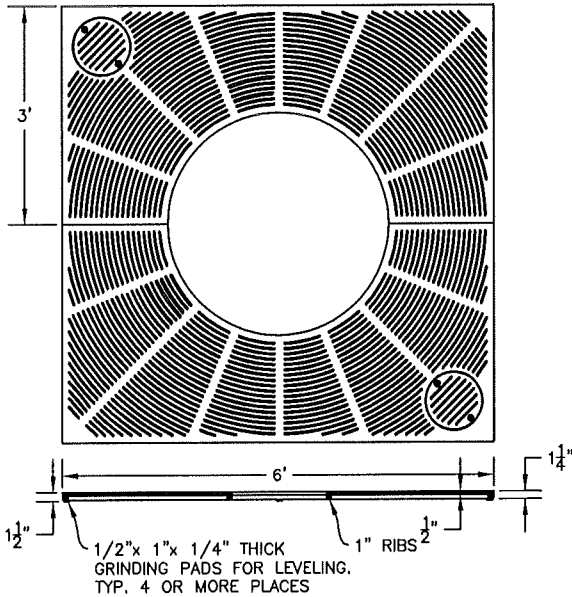

**OUTER GRATE**

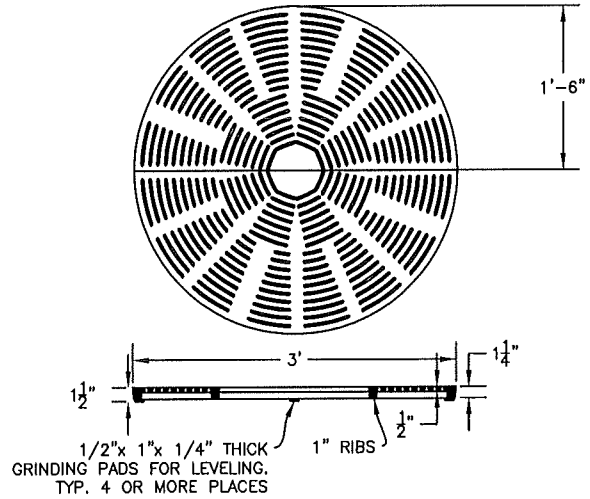

**INNER GRATE**

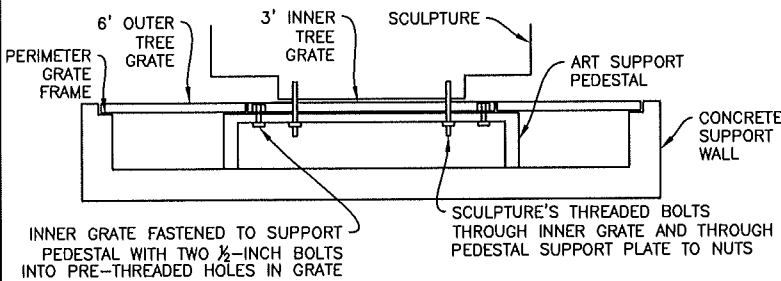

**FRAME & GRATE DETAILS, N.T.S.**

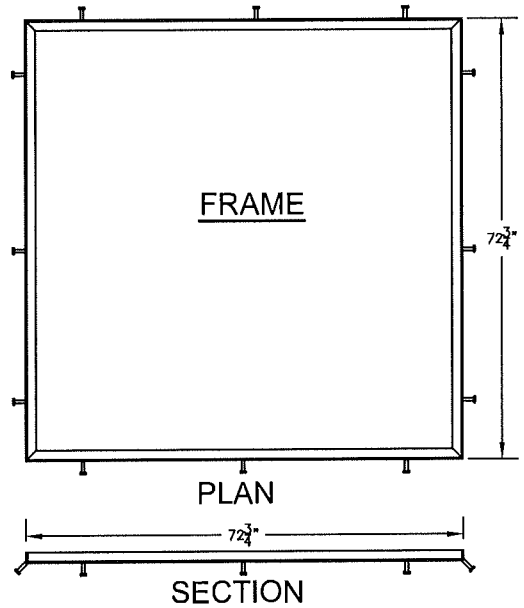

**GRATE FRAME NOTES**

1. IRONSMITH TREE GRATE FRAME MODEL 7200F OR APPROVED EQUAL, SQUARE TREE GRATE FRAME WITH STANDARD CONCRETE ANCHORS.
2. FRAME JIG WELDED FROM 1-3/4" x 1-3/4" STEEL ANGLE PER ASTM A36. ANCHORS 1/2" NELSON.
3. ANCHORS MACHINE WELDED TO FRAME. FRAME TO BE HOT DIPPED GALVANIZED.

**CITY OF SALEM**  
**DEPARTMENT OF PUBLIC WORKS**  
 STANDARD PLAN  
**STREETSCAPE ART MOUNTING VAULT**  
 FRAME AND GRATE DETAILS

APPROVED			DRAWN BY	ALT	01/2016	<b>NO. 8XY</b>
	CITY ENGINEER	DATE	CHECKED BY	RWL	01/2016	



# NOTICE OF DECISION

PLANNING DIVISION  
555 LIBERTY ST. SE, RM 305  
SALEM, OREGON 97301  
PHONE: 503-588-6173  
FAX: 503-588-6005



*Si necesita ayuda para comprender esta informacion, por favor llame (503) 588-6173*

## ADMINISTRATIVE DECISION – MINOR HISTORIC REVIEW

**CASE NO.:** Historic Review Case HIS14-21MOD / AMANDA No. 14-117245-DR

**DECISION DATE:** November 5, 2014

**REQUEST:** Minor administrative historic design review to modify the administrative decision (HIS14-21) approving installation of 9 "Art Wells" at sidewalk corner locations, to 6 "Art Wells" at sidewalk corner locations within the Downtown Salem Historic District, on properties zoned CB (Central Business District). The applicant does not propose any changes to the design of the Art Wells, each of which would consist of a 6 by 6 square foot opening in the sidewalk covered by a cast iron grate, similar to the approved tree well design.

**APPLICANT:** City of Salem, Public Works Department

**CONTACT:** Todd Klocke, Project Coordinator

**LOCATION:** Various sites within the Salem Downtown Historic District

**CRITERIA:** Salem Revised Code (SRC) Chapter 230

**FINDINGS:** The applicant requests to modify the June 26, 2014 decision by the Urban Planning Administrator (HIS14-21 / AMANDA No. 14-110995-DR) to approve installation of "Art Wells" at 9 sidewalk corner locations within the Downtown Salem Historic District. In the modified proposal, the applicant proposes a total of 6 sidewalk corner locations within the Historic District, including 4 that remain unchanged from the original proposal.

In HIS14-21, staff reviewed the proposal for art wells for compliance with the standards for streetscape improvements in commercial historic districts as provided in SRC 230.075(a) and (b). Staff found that the decorative pattern of the cast iron grating is compatible with the character of the streetscape within the historic district, and that no significant historic sidewalk features that contribute to the Downtown Historic District would be disturbed by the installation of the proposed art wells. The applicant has not proposed any changes to the design of the art wells or the method of installation. Staff has reviewed the request for modification and finds that the new proposed locations for art wells would not affect compliance with the standards of SRC 230.075.

**DECISION:** Based upon the application materials deemed complete on October 15, 2014, and the findings as presented in this report, the application is APPROVED.

Christopher Green, Planner II  
Urban Planning Administrator Designee  
[cgreen@cityofsalem.net](mailto:cgreen@cityofsalem.net)  
Phone: (503) 540-2326

Application Deemed Complete: October 15, 2014  
Notice of Decision Mailing Date: November 5, 2014  
Decision Effective Date: November 21, 2014  
State Mandated Decision Date: February 12, 2015

The rights granted by this decision must be exercised by November 21, 2016 or this approval shall be null and void.

This decision is final unless written appeal from an aggrieved party is filed with the City of Salem Planning Division, Room 305, 555 Liberty Street SE, Salem, OR 97301, no later than **5:00 p.m., November 20, 2014**. The appeal must state where the decision failed to conform to the provisions of the historic preservation ordinance (SRC Chapter 230). The appeal must be filed in duplicate with the City of Salem Planning Division. The appeal fee must be paid at the time of filing. If the appeal is untimely and/or lacks the proper fee, the appeal will be rejected. The Salem Historic Landmarks Commission will review the appeal at a public hearing. After the hearing, the Historic Landmarks Commission may amend, rescind, or affirm the action, or refer the matter to staff for additional information.

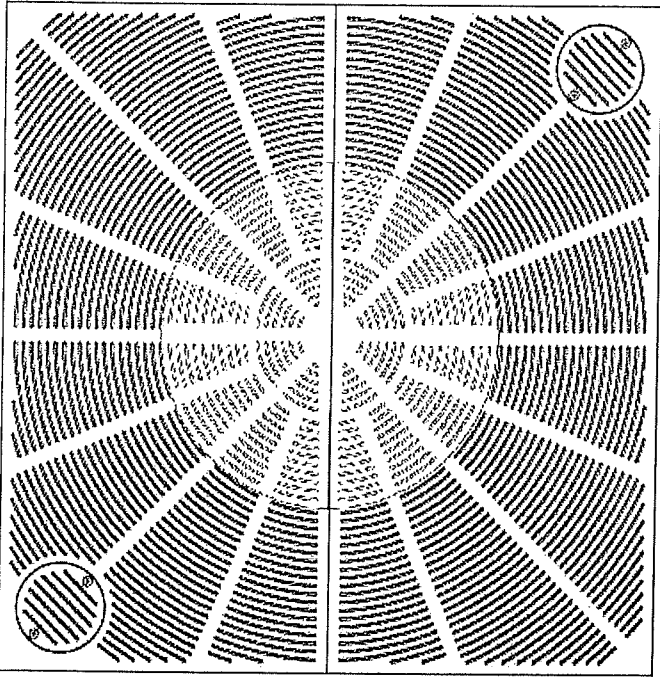
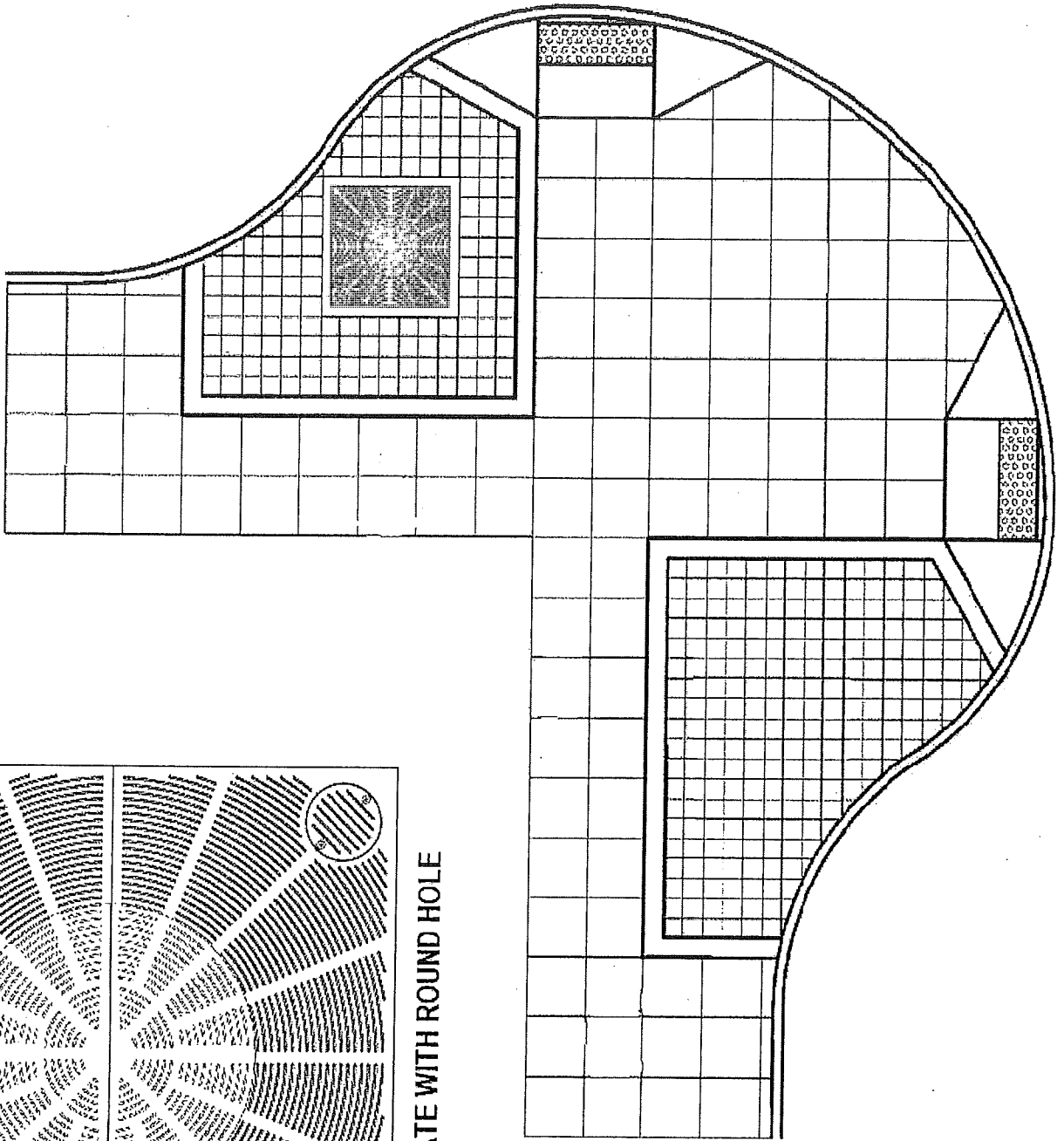

SQUARE GRATE WITH ROUND HOLE

**TEN CITY-APPROVED SCULPTURE LOCATIONS**  
**8/7/2014**

